

## Operating Instructions

### WARNING

WARNING .....	6
CAUTION .....	6
PRECAUTIONS .....	6

### Getting Started

Accessory List .....	9
Turning Power On and Off .....	9
Demonstration Function .....	9
Turning the Demonstration mode Off .....	9
Source Selection.....	9
Detaching and Attaching the Front Panel (Only for CDE-164EBT).....	9
Detaching .....	9
Attaching .....	10
Initial System Start-Up.....	10
Adjusting Volume .....	10
Setting the Dimmer Control.....	10
Setting Time.....	10

### Radio

Listening to Radio.....	11
Presetting Stations Manually .....	12
Presetting Stations Automatically.....	12
Tuning to Preset Stations .....	12
Frequency Search Function.....	12

### CD/MP3/WMA/AAC

Playback .....	12
Repeat and Random Play .....	13
Searching for CD Text .....	13
Folder/File Name Search (concerning MP3/WMA/AAC).....	13
Folder Name Search mode.....	13
File Name Search mode.....	13
Search Position Memory .....	14
About MP3/WMA/AAC.....	14
Terminology.....	15

## Sound Setting

Adjusting Subwoofer Level/Bass Level/ Treble Level/Balance (Between Left and Right)/ Fader (Between Front and Rear)/Defeat.....	15
Sound Setting .....	16
Equalizer Presets .....	16
Setting BASS ENGINE SQ ON/OFF .....	16
Displaying the BASS ENGINE SQ PARAMETER .....	16
Adjusting the Parametric Equalizer Curve (9BAND P-EQ).....	16
Adjusting the Frequency (CENTER FRQ) .....	17
Setting the Bandwidth (WIDTH (Q)) .....	17
Adjusting the Level (LEVEL).....	17
Setting the Source Volume Level.....	17
Adjusting the Crossover Settings (X-OVER).....	17
Selecting the Cut-Off Frequency (FREQUENCY).....	17
Adjusting the Slope (SLOPE) .....	17
Adjusting the Level (LEVEL).....	17
Turning Subwoofer ON/OFF .....	17
Setting the Subwoofer Phase.....	18
Setting the Subwoofer System .....	18
Setting the Time Correction Unit (LENGTH) .....	18
Adjusting the Time Correction (TCR).....	18
External Device.....	18
Connecting to an External Amplifier (POWER IC).....	18
Setting the Media Xpander mode.....	19
BASS ENGINE SQ Function.....	19
Switching BASS ENGINE SQ mode .....	19
Adjusting BASS ENGINE SQ Level .....	19
About Time Correction .....	19
Example 1. Listening Position: Front Left Seat.....	19
Example 2. Listening Position: All Seats .....	20
About the Crossover.....	21

## Other Functions

Displaying the Text.....	23
About "Text" .....	23
Using the Front AUX Input Terminal.....	23
Option Menu Setting .....	24
Applying Tunelt.....	24
Adjusting the sound via the Smartphone ...	25
Facebook Notification Function .....	25
Receiving Notification .....	25
Displaying Notification List.....	25

## SETUP

Setting.....	26
General Setting.....	26
Setting the Clock Display (CLOCK MODE).....	26
Turning the Clock Display ON/OFF.....	26
Setting the AUX SETUP mode.....	26
Setting the AUX NAME mode.....	27
Playing MP3/WMA/AAC Data (PLAY MODE).....	27
Setting the stay on mode.....	27
Demonstration.....	27
Display Setting.....	27
Changing Lighting Color.....	27
Dimmer Control.....	27
Scroll Setting (TEXTSCROLL).....	28
Scroll Type Setting.....	28
Tuner Setting.....	28
Setting the TUNER (FM) tone quality (FM SET).....	28
iPod Setting.....	28
iPod/iPhone Search Mode Setting.....	28
Application Setting (APP).....	28
Setting the communication mode with a Smartphone (ALPINE APP).....	28
Setting the TTS (Text To Speech) volume.....	28

## BT Hands Free Calling

Setup Before Using.....	29
About Bluetooth®.....	29
Before Using Bluetooth Function.....	29
How to connect to a Bluetooth compatible device (Pairing).....	29
For Bluetooth compatible device with SSP (Secure Simple Pairing).....	29
For Bluetooth compatible device without SSP (Secure Simple Pairing).....	29
Auto pairing with an iPod/iPhone.....	29
Bluetooth SETUP.....	30
Setting the Bluetooth Connection (BT IN).....	30
Setting the Auto Pairing with iPod/iPhone.....	30
Setting the Bluetooth Device.....	30
Setting the Visible Mode.....	31
Setting the Bluetooth sound quality.....	31
Adjusting the volume (SOURCE VOL).....	31
Sound Auto setting (TYPE SET).....	31
Setting the caller information display ON/OFF.....	31
Setting the Phone Book Update.....	31
Setting the Phone Book Auto Update ON/OFF (AUTO).....	31
Setting the Phone Book Manual Update ON/OFF (MANUAL).....	31

Changing the Phone book List Order.....	31
Selecting the output speaker.....	32
Displaying the firmware version.....	32
Updating the firmware.....	32
Hands-Free Phone Control.....	32
About the Hands-Free Phone.....	32
Answering a Call.....	32
Hanging up the Telephone.....	32
Calling.....	32
Redialing a Number In Outgoing History.....	33
Dialing a Number In Incoming History.....	33
Dialing a Number In Incoming Missed Call History.....	33
Dialing a Number In The Phone Book.....	33
Phone book Alphabet Search Function.....	33
Voice Control Operation.....	33
Call waiting function.....	33
Preset a number in the Phone Menu (Shortcut dial).....	34
Dialing the preset number.....	34
Adjusting the volume when receiving a Call.....	34
Muting the microphone input quickly (Voice Mute).....	34
Call Switching Operation.....	34
Bluetooth Audio Operation.....	34
Recalling the Bluetooth Audio Mode.....	34
Selecting the desired Song.....	34
Pausing.....	34
Selecting the desired Group.....	34
Searching for a desired song.....	35

## USB Memory (optional)

Playback MP3/WMA/AAC Files from USB Memory (optional).....	35
About MP3/WMA/AAC File of USB Memory ...	36

## iPod/iPhone (optional)

Connecting an iPod/iPhone.....	37
Setting the iPod Control.....	37
Playback.....	37
Searching for a desired Song.....	38
Direct Search Function.....	38
Select Playlist/Artist/Album/Genre/Composer/ Episode.....	39
Alphabet Search Function.....	39
Search Position Memory.....	39
Random Play Shuffle (M.I.X.).....	39
Repeat Play.....	39
Displaying the Text.....	40

## **Pandora® internet radio (Optional)**

Listening to Pandora® .....	41
“Thumbs” Feedback.....	41
Searching for a Desired Station .....	41
Shuffle .....	41
Bookmarking a Desired Song or Artist.....	42
Creating a New Station .....	42
Search Position Memory .....	42
Changing the Display .....	42

## **Information**

In Case of Difficulty.....	43
Basic .....	43
Radio.....	43
CD .....	43
MP3/WMA/AAC .....	43
Audio .....	43
iPod .....	43
Indication for CD Player .....	43
Indication for USB Memory .....	44
Indication for iPod Mode.....	44
Bluetooth mode .....	45
Indication for Pandora® Mode .....	45
Specifications .....	46

---

## **Installation and Connections**

<b>WARNING .....</b>	<b>47</b>
<b>CAUTION .....</b>	<b>47</b>
<b>PRECAUTIONS .....</b>	<b>47</b>
Installation .....	48
Removal.....	49
Mounting the Microphone.....	49
Connections.....	50

# Operating Instructions

## WARNING

### WARNING

**This symbol means important instructions. Failure to heed them can result in serious injury or death.**

#### **DO NOT OPERATE ANY FUNCTION THAT TAKES YOUR ATTENTION AWAY FROM SAFELY DRIVING YOUR VEHICLE.**

Any function that requires your prolonged attention should only be performed after coming to a complete stop. Always stop the vehicle in a safe location before performing these functions. Failure to do so may result in an accident.

#### **KEEP THE VOLUME AT A LEVEL WHERE YOU CAN STILL HEAR OUTSIDE NOISES WHILE DRIVING.**

Excessive volume levels that obscure sounds such as emergency vehicle sirens or road warning signals (train crossings, etc.) can be dangerous and may result in an accident. LISTENING AT LOUD VOLUME LEVELS IN A CAR MAY ALSO CAUSE HEARING DAMAGE.

#### **MINIMIZE DISPLAY VIEWING WHILE DRIVING.**

Viewing the display may distract the driver from looking ahead of the vehicle and cause an accident.

#### **DO NOT DISASSEMBLE OR ALTER.**

Doing so may result in an accident, fire or electric shock.

#### **USE ONLY IN CARS WITH A 12 VOLT NEGATIVE GROUND.**

(Check with your dealer if you are not sure.) Failure to do so may result in fire, etc.

#### **KEEP SMALL OBJECTS SUCH AS BATTERIES OUT OF THE REACH OF CHILDREN.**

Swallowing them may result in serious injury. If swallowed, consult a physician immediately.

#### **USE THE CORRECT AMPERE RATING WHEN REPLACING FUSES.**

Failure to do so may result in fire or electric shock.

#### **DO NOT BLOCK VENTS OR RADIATOR PANELS.**

Doing so may cause heat to build up inside and may result in fire.

#### **USE THIS PRODUCT FOR MOBILE 12V APPLICATIONS.**

Use for other than its designed application may result in fire, electric shock or other injury.

#### **DO NOT PLACE HANDS, FINGERS OR FOREIGN OBJECTS IN INSERTION SLOTS OR GAPS.**

Doing so may result in personal injury or damage to the product.

### CAUTION

**This symbol means important instructions. Failure to heed them can result in injury or material property damage.**

#### **HALT USE IMMEDIATELY IF A PROBLEM APPEARS.**

Failure to do so may cause personal injury or damage to the product. Return it to your authorized Alpine dealer or the nearest Alpine Service Center for repairing.

### PRECAUTIONS

#### **Product Cleaning**

Use a soft dry cloth for periodic cleaning of the product. For more severe stains, please dampen the cloth with water only. Anything else has the chance of dissolving the paint or damaging the plastic.

#### **Temperature**

Be sure the temperature inside the vehicle is between +60°C (+140°F) and -10°C (+14°F) before turning your unit on.

#### **Moisture Condensation**

You may notice the CD playback sound wavering due to condensation. If this happens, remove the disc from the player and wait about an hour for the moisture to evaporate.

#### **Damaged Disc**

Do not attempt to play cracked, warped, or damaged discs. Playing a bad disc could severely damage the playback mechanism.

#### **Maintenance**

If you have problems, do not attempt to repair the unit yourself. Return it to your Alpine dealer or the nearest Alpine Service Station for servicing.

#### **Never Attempt the Following**

Do not grip or pull out the disc while it is being pulled back into the player by the automatic reloading mechanism. Do not attempt to insert a disc into the unit when the unit power is off.

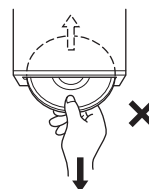

## Inserting Discs

Your player accepts only one disc at a time for playback. Do not attempt to load more than one disc.

Make sure the label side is facing up when you insert the disc. "ERROR" will be displayed on your player if you insert a disc incorrectly. If "ERROR" continues to be displayed even though the disc has been inserted correctly, push the **RESET** switch with a pointed object such as a ballpoint pen.

Playing a disc while driving on a very bumpy road may result in skips, but this will not scratch the disc or damage the player.

## New Discs

To prevent the CD from jamming, "ERROR" is displayed if discs with irregular surfaces are inserted or if discs are inserted incorrectly. When a new disc is ejected immediately after initial loading, use your finger to feel around the inside of the center hole and outside edge of the disc. If you feel any small bumps or irregularities, this could inhibit proper loading of the disc. To remove the bumps, rub the inside edge of the hole and outside edge of the disc with a ballpoint pen or other such instrument, and then insert the disc again.

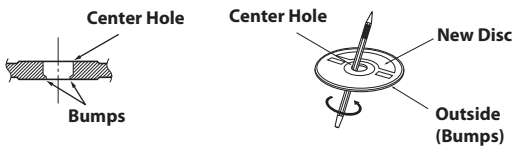

## Irregular Shaped Discs

Be sure to use round discs only for this unit and never use any special shaped discs. Use of special shape discs may cause damage to the mechanism.



## Installation Location

Make sure this unit will not be installed in a location subjected to:

- Direct sun and heat
- High humidity and water
- Excessive dust
- Excessive vibrations

## Correct Handling

Do not drop the disc while handling. Hold the disc so you will not leave fingerprints on the surface. Do not affix tape, paper, or gummed labels to the disc. Do not write on the disc.

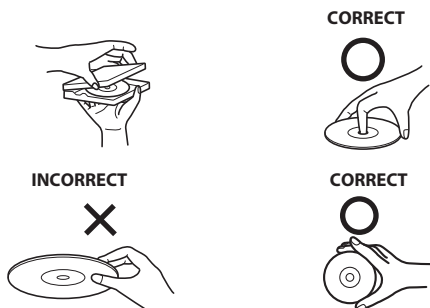

## Disc Cleaning

Fingerprints, dust, or soil on the surface of the disc could cause the CD player to skip. For routine cleaning, wipe the playing surface with a clean, soft cloth from the center of the disc to the outer edge. If the surface is heavily soiled, dampen a clean, soft cloth in a solution of mild neutral detergent before cleaning the disc.



## Disc Accessories

There are various accessories available on the market for protecting the disc surface and improving sound quality. However, most of them will influence the thickness and/or diameter of the disc. Using such accessories can cause the disc to be out of standard specifications and may create operational problems. We recommend not using these accessories on discs played in Alpine CD players.

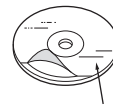

Transparent Sheet

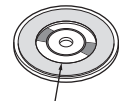

Disc Stabilizer

## On handling Compact Discs (CD/CD-R/CD-RW)

- Do not touch the surface.
- Do not expose the disc to direct sunlight.
- Do not affix stickers or labels.
- Clean the disc when it is dusty.
- Make sure that there are no bumps around the disc.
- Do not use commercially available disc accessories.

**Do not leave the disc in the car or the unit for a long time. Never expose the disc to direct sunlight.** Heat and humidity may damage the CD and you may not be able to play it again.

## To customers using CD-R/CD-RW

- If a CD-R/CD-RW cannot be played back, make sure the last recording session was closed (finalized).
- Finalize the CD-R/CD-RW if necessary, and attempt playback again.

## About media that can be played

Use only compact discs with the label side showing the CD logo marks below.



If you use non-standard compact discs, correct performance cannot be guaranteed.

You can play CD-Rs (CD-Recordables)/CD-RWs (CD-ReWritables) which have been recorded only on audio devices. You can also play CD-Rs/CD-RWs containing MP3/WMA/AAC formatted audio files.

- Some of the following CDs may not play on this unit:  
Flawed CDs, CDs with fingerprints, CDs exposed to extreme temperatures or sunlight (e.g., left in the car or this unit), CDs recorded under unstable conditions, CDs on which a recording failed or a re-recording was attempted, copy-protected CDs which do not conform to the audio CD industry standard.

- Use discs with compressed audio files written in a format compatible with this unit. For details, refer to “About MP3/WMA/AAC” on page 14.
- Data files, other than audio, on the disc are ignored and are not played back.

---

### Protecting the USB Port

- Only USB Memory devices or iPod/iPhone can be connected to the USB port on this unit. Correct performance using other USB products cannot be guaranteed. A USB hub is not supported.
- Depending on the shape or size of a USB device, it may not be connected to the USB terminal of this unit—a USB extension (sold separately) is recommended for this connection. For CDE-164EBT, also avoid connecting USB Memory and Front Aux at the same time.
- If a USB device is inserted in the unit, it projects out and may be a danger while driving. Use a commercially available USB extension cable, and connect it in a safe way.
- Depending on the connected USB Memory device, the unit may not function or some functions may not be performed.
- The audio file format that can be played back on the unit is MP3/WMA/AAC.
- Artist/song name, etc., can be displayed, however some characters may not be correctly displayed.

---

### On Handling USB Memory

#### CAUTION

**Alpine accepts no responsibility for lost data, etc., even if data, etc., is lost while using this product.**

- To prevent malfunction or damage, note the following points. Read the USB Memory Owner’s Manual thoroughly.
- Fix the USB Memory in a location where driver operation will not be hindered.
- USB Memory may not function correctly at high or low temperature.
- Use only certified USB Memory Devices. Please pay attention that even certified USB Memory, may not function correctly depending on its type or state.
- USB Memory function is not guaranteed. Use USB Memory according to the terms of agreement.
- Depending on the settings of the USB Memory type, memory state or encoding software, the unit may not play back or display properly.
- A file that is copy-protected (copyright protection) cannot be played back.
- USB Memory may take time to start playback. If there is a particular file other than audio in the USB Memory, it may take considerable time before the file is played back or searched.
- The unit can play back “mp3” or “wma” file extensions.
- Do not add the above extensions to a file other than audio data. This non-audio data will not be recognized. The resulting playback may contain noise that can damage speakers and/or amplifiers.
- It is recommended to back up important data on a personal computer.
- Do not remove the USB device while playback is in progress. Change SOURCE to something other than USB, and then remove the USB device to prevent possible damage to its memory.

- *Windows Media and the Windows logo are trademarks, or registered trademarks of Microsoft Corporation in the United States and/or other countries.*
- *iPhone, iPod, iPod classic, iPod nano and iPod touch are trademarks of Apple Inc., registered in the U.S. and other countries.*
- *“Made for iPod,” and “Made for iPhone,” mean that an electronic accessory has been designed to connect specifically to iPod, or iPhone, respectively, and has been certified by the developer to meet Apple performance standards. Apple is not responsible for the operation of this device or its compliance with safety and regulatory standards. Please note that the use of this accessory with iPod, or iPhone may affect wireless performance.*
- *The Bluetooth® word mark and logos are registered trademarks owned by the Bluetooth SIG, Inc. and any use of such marks by Alpine Electronics, Inc. is under licence.*
- *MPEG Layer-3 audio coding technology licensed from Fraunhofer IIS and Thomson. Supply of this product only conveys a licence for private, non-commercial use and does not convey a licence nor imply any right to use this product in any commercial (i.e. revenue-generation) real time broadcasting (terrestrial, satellite, cable and/or any other media), broadcasting/streaming via internet, intranets and/or other networks or in other electronic content distribution systems, such as pay-audio or audio-on-demand applications. An independent licence for such use is required. For details, please visit <http://www.mp3licensing.com>*
- *Pandora, the Pandora logo, and the Pandora trade dress are trademarks or registered trademarks of Pandora Media, Inc., used with permission. Pandora is currently available in the U.S., Australia and New Zealand.*
- *Android is a trademark of Google Inc.*
- *The Android robot is reproduced or modified from work created and shared by Google and used according to terms described in the Creative Commons 3.0 Attribution License.*
- *BlackBerry®, RIM®, Research In Motion® and related trademarks, names and logos are the property of Research In Motion Limited and are registered and/or used in the U.S. and countries around the world. Used under license from Research In Motion Limited.*

# Getting Started

## CDE-W265EBT

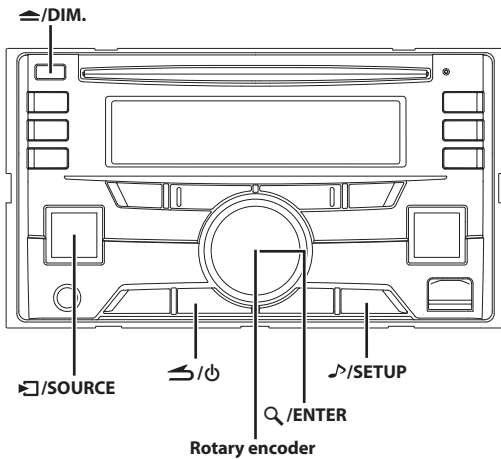

## CDE-164EBT

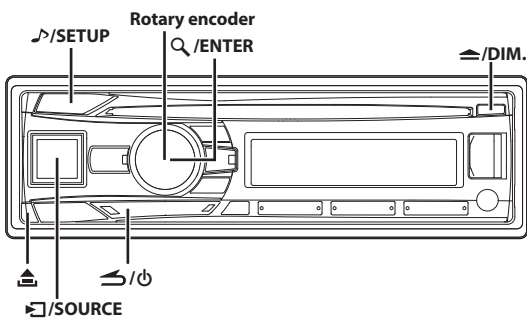

## Accessory List

• Head Unit .....	1
• Power Cable .....	1
• Microphone .....	1
• Mounting Sleeve .....	1
• Carrying Case* .....	1
• Bracket Key .....	2
• Screw (M5 × 8) .....	4
• Remote Control .....	1
• Owner's Manual .....	1 set

\* Only for CDE-164EBT.

## Turning Power On and Off

Press **⏻/⏪** to turn on the unit.

### Note

- The unit can be turned on by pressing any other button except **▲** and **▲\*** (Release).

\* Only for CDE-164EBT.

Press and hold **⏻/⏪** for at least 2 seconds to turn off the unit.

### Note

- The first time power is turned on, the volume will start from level 0.

## Demonstration Function

This unit will enter a demonstration mode to display its various functions. When Demo mode is set to ON (initial setting), the unit starts the demonstration if there is no operation for 30 seconds.

### Turning the Demonstration mode Off

There are two methods to close the demonstration mode.

#### Method 1:

When installing this unit in a car for the first time, the DEMO OFF screen will be displayed for 20 seconds after turning on the unit. Press **Q/ENTER** within 20 seconds to put the demonstration mode into standby state\*.

#### Method 2:

Setting DEMO MODE to OFF (standby state\*) or QUITE OFF (completely closed state\*) in Setup menu.

\* For details about standby state and completely closed state, please refer to "Demonstration" on page 27.

## Source Selection

Press **↵/SOURCE** to change the source.

TUNER → DISC → USB AUDIO/iPod\*<sup>1</sup> → BT AUDIO\*<sup>2</sup> → PANDORA\*<sup>3</sup> → AUXILIARY\*<sup>4</sup> → TUNER

\*<sup>1</sup> Displayed only when the iPod/iPhone is connected.

\*<sup>2</sup> Displayed only when BT IN is set to ON, refer to "Setting the Bluetooth Connection (BT IN)" on page 30.

\*<sup>3</sup> Not displayed when ALPINE APP is set to OFF, refer to "Setting the communication mode with a Smartphone (ALPINE APP)" on page 28.

\*<sup>4</sup> Refer to "Using the Front AUX Input Terminal" on page 23.

## Detaching and Attaching the Front Panel (Only for CDE-164EBT)

### Detaching

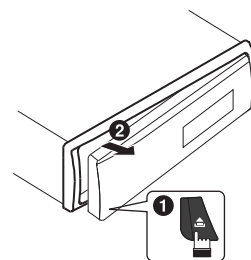

### Notes

- The front panel may become hot in normal usage (especially the connector terminals on the back of the front panel). This is not a malfunction.
- To protect the front panel, place it in the supplied carrying case.
- When detaching the front panel, do not apply excessive force as it may result in malfunction.

## Attaching

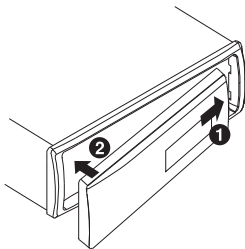

### Notes

- Before attaching the front panel, make sure that there is no dirt or dust on the connector terminals and no foreign object between the front panel and the main unit.
- Attach the front panel carefully, holding the sides of the front panel to avoid pushing buttons by mistake.

## Initial System Start-Up

Be sure to press the **RESET** switch when using the unit for the first time, after changing the car battery, etc.

### ■ CDE-W265EBT

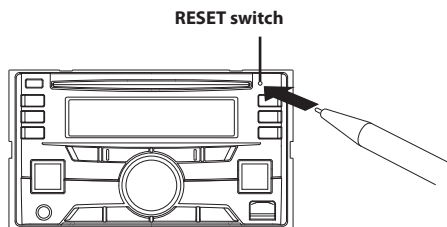

### ■ CDE-164EBT

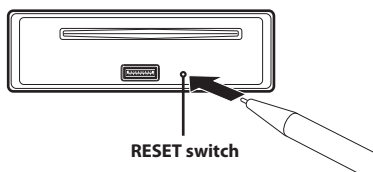

## Adjusting Volume

Turn the **Rotary encoder** until the desired sound is obtained.

## Setting the Dimmer Control

Press and hold **DIM.** for at least 2 seconds repeatedly to select the **DIMMER** mode.

DIMMER AUTO → DIMMER ON → DIMMER OFF → DIMMER AUTO

### **DIMMER AUTO** mode:

Decrease the illumination brightness of the unit's buttons with the head lights of the vehicle ON. This mode decreases the unit's backlighting in sync with headlight usage.

### **DIMMER ON** mode:

Keep the illumination brightness of the backlighting dimmed.

### **DIMMER OFF** mode:

Keep the illumination brightness of the backlighting bright.

### Note

- The setting items are the same as **DISPLAY** setting in **SETUP** mode. For details, refer to "Dimmer Control" on page 27.

## Setting Time

- 1 Press and hold **♪ / SETUP** for at least 2 seconds to activate the **SETUP** selection mode.
- 2 Turn the **Rotary encoder** to select **GENERAL**, and then press **Q / ENTER**.
- 3 Turn the **Rotary encoder** to select the **CLOCK ADJ** mode, and then press **Q / ENTER**.  
The time indication will blink.
- 4 Turn the **Rotary encoder** to adjust the hours while the time indication is blinking.
- 5 When the hour has been adjusted, press **Q / ENTER**.
- 6 Turn the **Rotary encoder** to adjust the minutes while the time indication is blinking.
- 7 Press and hold **♪ / SETUP** for at least 2 seconds to return to normal mode.

### Notes

- To synchronize the clock to another clock/watch or radio time announcement, press and hold **Q / ENTER** for at least 2 seconds after setting the "hour". Minutes will reset to "00". If the display shows over "30" minutes when you do this, the time will advance one hour.
- Pressing **↵** will return to the previous mode.
- If no operation is performed for 60 seconds, the unit will return to normal mode automatically.



### Controllable with Remote Control

This unit can be controlled with an optional Alpine remote control. For details, consult your Alpine dealer. Point the optional remote control transmitter at the remote control sensor.

#### CDE-W265EBT

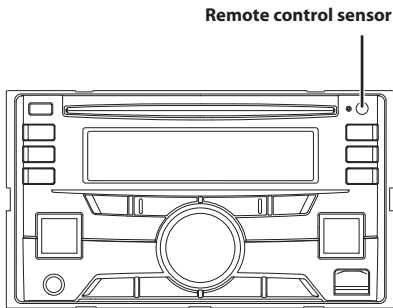

#### CDE-164EBT

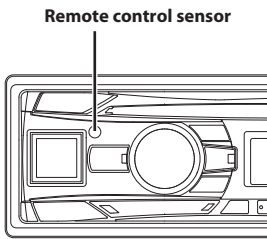

### Connectable to Remote Control Interface Box

With an optional Alpine Steering Wheel Remote Control Interface Box (not included), this unit is controllable from the vehicle's steering wheel controls. For details, contact your Alpine dealer.

## Radio

#### CDE-W265EBT

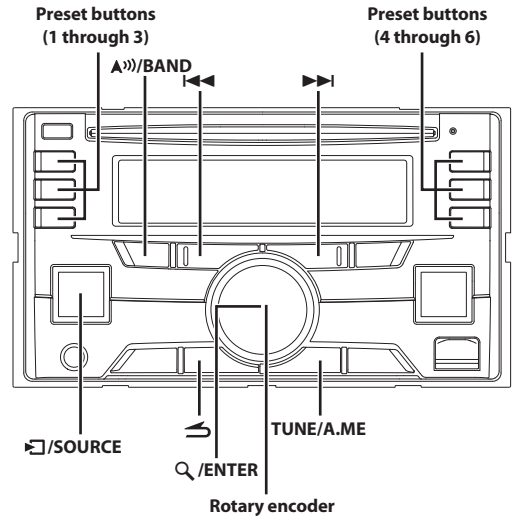

#### CDE-164EBT

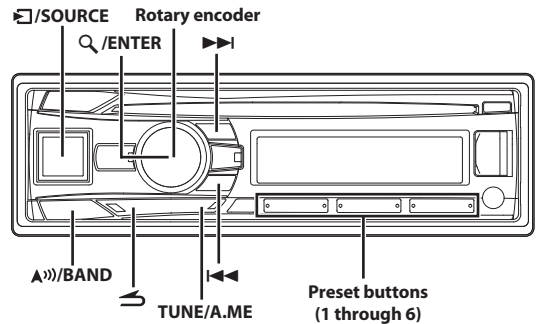

## Listening to Radio

- 1 Press ☐ /SOURCE to select TUNER mode.
- 2 Press A)))/BAND repeatedly until the desired radio band is displayed.  
FM1 → FM2 → AM → FM1
- 3 Press TUNE/A.ME to select the tuning mode.  
DX SEEK (Distance mode) → LOCAL SEEK (Local mode) →  
MANUAL (Manual mode) → DX SEEK

### Note

- The initial mode is Distance mode.

### Distance mode:

Both strong and weak stations will be automatically tuned in (Automatic Seek Tuning).

### Local mode:

Only strong stations will be automatically tuned in (Automatic Seek Tuning).

### Manual mode:

The frequency is manually tuned in steps (Manual tuning).

- 4 Press ◀◀ or ▶▶ to tune in the desired station.  
Holding down ◀◀ or ▶▶ will change the frequency continuously.

## Presetting Stations Manually

While receiving the station that you want to store, press and hold, for at least 2 seconds, any one of the **preset buttons (1 through 6)** into which you wish to store the station.

The display shows the band, preset number and station frequency memorized.

### Notes

- A total of 18 stations can be stored in the preset memory (6 stations for each band; FM1, FM2 and AM).
- If you store a station in a preset memory which already has a station, the current station will be cleared and replaced with the new station.

## Presetting Stations Automatically

- 1 Press **▲/BAND** repeatedly until the desired radio band is displayed.

- 2 Press and hold **TUNE/A.ME** for at least 2 seconds.

The frequency on the display continues to change while the automatic memory is in progress. The tuner will automatically seek and store 6 strong stations in the selected band. They will be stored into preset buttons 1 to 6 in order of signal strength. When the automatic memory has been completed, the tuner goes to the station stored in preset location No.1.

### Note

- If no stations are stored, the tuner will return to the original station you were listening to before the auto memory procedure began.

## Tuning to Preset Stations

Select the band, and then press any one of the station **preset buttons (1 through 6)** that has your desired radio station in memory.

The display shows the band, preset number and frequency of the station selected.

## Frequency Search Function

You can search for a radio station by its frequency.

- 1 Press **Q/ENTER** in Radio mode to activate Frequency search mode.
- 2 Turn the **Rotary encoder** to select the desired frequency.
- 3 Press **Q/ENTER** to receive the selected frequency.

### Note

- Press **↵** in the search mode to cancel. Or, the search mode will be canceled if no operation is performed for 60 seconds.

## CD/MP3/WMA/AAC

### ■ CDE-W265EBT

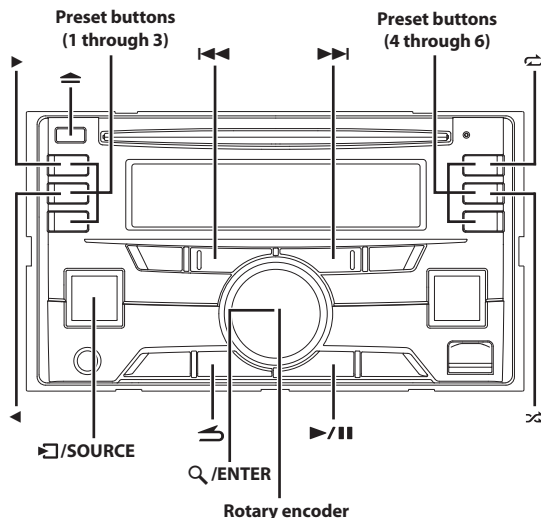

### ■ CDE-164EBT

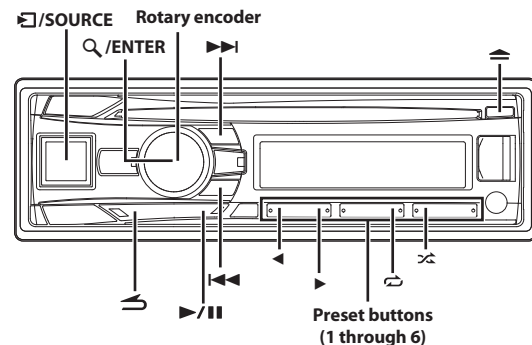

## Playback

- 1 Insert a disc with the label side facing up.  
The disc will be pulled into the unit automatically.

### ■ CDE-W265EBT

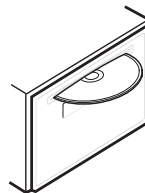

## CDE-164EBT

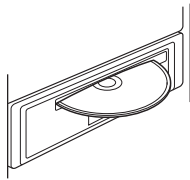

### Note

- When a disc is already inserted, press **⏮** /SOURCE to switch to the DISC mode.

**2** While playing back MP3/WMA/AAC, press **◀** or **▶** to select the desired folder.

**3** Press **◀◀** or **▶▶** to select the desired track (file).

Pressing and holding **◀◀** or **▶▶** will fast backward/fast forward track continuously.

**4** To pause playback, press **⏮**.

Pressing **⏮** again will resume playback.

**5** To eject the disc, press **⏮**.

### Notes

- Do not remove a CD during its eject cycle. Do not load more than one disc at a time. A malfunction may result from doing either.
- Three-inch (8 cm) CDs cannot be used.
- Any file protected by DRM (Digital Rights Management) copy protection, cannot be played back on this unit.
- The track display for MP3/WMA/AAC data playback is the file numbers recorded on the disc.
- The playback time may not be correctly displayed when a VBR (Variable Bit Rate) recorded file is played back.

## Repeat and Random Play

**1** During playback, Press **⏮** or **⏮** repeatedly until the setting appears.

#### REPEAT ONE:

Track/file is played back repeatedly.

#### REPEAT FOLDER\*:

Files in a folder are played back repeatedly.

#### MIX FOLDER\*:

Files in a folder are played back randomly.

#### MIX ALL:

All files in the disc or USB Memory are played back randomly.

\* When MP3/WMA/AAC files are played back.

**2** To cancel repeat or M.I.X. play, select (OFF) with the above procedure.

### Notes

- ⏮** indicator lights up during repeat play mode.
- ⏮** indicator lights up during random play mode.

## Searching for CD Text

On discs utilizing CD Text, songs can be searched and played by using their recorded titles. For discs without CD Text, searches are made using the track numbers associated with each song.

**1** Press **⏮** /ENTER during play.

**2** Turn the **Rotary encoder** to select the desired track, and then press **⏮** /ENTER.

This will play the selected track.

### Notes

- Press any of the **preset buttons (1 through 6)** during a search to skip over a calculated percentage of tracks. For details, refer to "Direct Search Function" on page 38.
- Press **⏮** in the search mode to cancel. Or, the search mode is canceled if no operation is performed for 60 seconds.
- When CD Text Search is made during M.I.X. play, the M.I.X. play mode will be canceled.

## Folder/File Name Search (concerning MP3/WMA/AAC)

Folder and file names may be searched and displayed during playback.

### Folder Name Search mode

**1** During MP3/WMA/AAC playback, press **⏮** /ENTER to activate the search mode.

**2** Turn the **Rotary encoder** to select Folder Name Search mode, and then press **⏮** /ENTER.

**3** Turn the **Rotary encoder** to select the desired folder.

**4** Press and hold **⏮** /ENTER for at least 2 seconds to play back the first file in the selected folder.

### Notes

- Press any of the **preset buttons (1 through 6)** during a Folder Name search to skip over a calculated percentage of folders. For details, refer to "Direct Search Function" on page 38.
- Press **⏮** in the search mode to return to the previous mode. Or, the search mode is canceled if no operation is performed for 60 seconds.
- To search for files in the Folder Name Search mode, press **⏮** /ENTER. Files in the folder may be searched.
- The root folder is displayed as "ROOT".
- When Folder Name Search is made during M.I.X. play, the M.I.X. play mode will be canceled.

### File Name Search mode

**1** During MP3/WMA/AAC playback, press **⏮** /ENTER to activate the search mode.

**2** Turn the **Rotary encoder** to select File Name Search mode, and then press **⏮** /ENTER.

**3** Select the desired file by turning the **Rotary encoder**.

**4** Press **⏮** /ENTER to play back the selected file.

### Notes

- Press any of the **preset buttons (1 through 6)** during a File name search to skip over a calculated percentage of files. For details, refer to "Direct Search Function" on page 38.
- Press **⏮** in the search mode to return to the previous mode. Or, the search mode is canceled if no operation is performed for 60 seconds.
- When File Name Search is made during M.I.X. play, the M.I.X. play mode will be canceled.

## Search Position Memory

During playback, you can quickly return to the last-selected hierarchy level in the search mode.

Press **↵**.

The hierarchy you selected last in the search mode is displayed.

## About MP3/WMA/AAC

### CAUTION

**Except for private use, duplicating audio data (including MP3/WMA/AAC data) or distributing, transferring, or copying it, whether for free or for a fee, without permission of the copyright holder is strictly prohibited by the Copyright Act and by international treaty.**

#### What is MP3?

MP3, whose official name is "MPEG Audio Layer 3," is a compression standard prescribed by the ISO, the International Standardization Organization and MPEG which is a joint activity institution of the IEC. MP3 files contain compressed audio data. MP3 encoding is capable of compressing audio data at extremely high ratios, reducing the size of music files to as much as one-tenth their original size. This is achieved while still maintaining near CD quality. The MP3 format realizes such high compression ratios by eliminating the sounds that are either inaudible to the human ear or masked by other sounds.

#### What is WMA?

WMA, or "Windows Media™ Audio," is compressed audio data. WMA is similar to MP3 audio data.

#### What is AAC?

AAC is the abbreviation for "Advanced Audio Coding," and is a basic format of audio compression used by MPEG2 or MPEG4.

#### Method for creating MP3/WMA/AAC files

Audio data is compressed using software with MP3/WMA/AAC codecs. For details on creating MP3/WMA/AAC files, refer to the user's manual for that software.

MP3/WMA/AAC files that are playable on this device have the file extensions "mp3" / "wma" / "m4a". Files with no extension cannot be played back (WMA ver. 7.1, 8 and 9 are supported). Protected files are not supported, neither are raw AAC files (using the ".aac" extension). There are many different versions of the AAC format. Confirm that the software being used conforms to the acceptable formats listed above. It's possible that the format may be unplayable even though the extension is valid.

Playback of AAC files encoded by iTunes is supported.

#### Supported playback sampling rates and bit rates

##### MP3

Sampling rates: 48 kHz, 44.1 kHz, 32 kHz, 24 kHz, 22.05 kHz, 16 kHz, 12 kHz, 11.025 kHz, 8 kHz

Bit rates: 8 - 320 kbps

##### WMA

Sampling rates: 48 kHz, 44.1 kHz, 32 kHz

Bit rates: 32 - 192 kbps

##### AAC

Sampling rates: 48 kHz, 44.1 kHz, 32 kHz, 24 kHz, 22.05 kHz, 16 kHz, 12 kHz, 11.025 kHz, 8 kHz

Bit rates: 16 - 320 kbps

This device may not play back correctly depending on sampling rates.

#### ID3 tags/WMA tags

This device supports ID3 tag v1 and v2, and WMA tag.

If tag data is in an MP3/WMA/AAC file, this device can display the title (track title), artist name, and album name ID3 tag/WMA tag data.

This device can only display single-byte alphanumeric characters (up to 30 for ID3 tags and up to 15 for WMA tags) and the underscore. For non-supported characters, "NO SUPPORT" is displayed or the character is displayed as space.

If information contains characters other than ID3 tag information, the audio file may not be played back.

The tag information may not be correctly displayed, depending on the contents.

#### Producing MP3/WMA/AAC discs

MP3/WMA/AAC files are prepared, then written to a CD-R or CD-RW using CD-R writing software. A disc can hold up to 509 files/255 folders. Playback may not be performed if a disc exceeds the limitations described above.

#### Media supported

The media that this device can play back are CD-ROMs, CD-Rs, and CD-RWs.

#### Corresponding File Systems

This device supports discs formatted with ISO9660 Level 1 or Level 2. Under the ISO9660 standard, there are some restrictions to remember. The maximum nested folder depth is 8 (including the root directory). The number of characters for a folder/file name is limited.

Valid characters for folder/file names are letters A-Z (all caps), numbers 0-9, and '\_' (underscore).

This device also can play back discs in Joliet, Romeo, etc., and other standards that conform to ISO9660. However, sometimes the file names, folder names, etc., are not displayed correctly.

#### Formats supported

This device supports CD-ROM XA, Mixed Mode CD, Enhanced CD (CD-Extra) and Multi-Session.

This device cannot correctly play back discs recorded with Track At Once or packet writing.

#### Order of files

Files are played back in the order that the writing software writes them to the disc. Therefore, the playback order may not be what is expected. Verify the writing order in the software's documentation. The playback order of the folders and files is as follows.

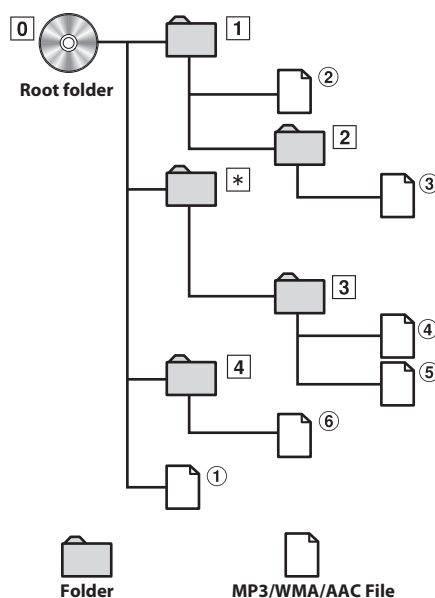

\* The folder No./ folder Name will not be displayed if no readable file is contained in the folder.

## Terminology

### Bit rate

This is the “sound” compression rate specified for encoding. The higher the bit rate, the higher the sound quality, but also the larger the files.

### Sampling rate

This value shows how many times per second the data is sampled (recorded). For example, music CDs use a sampling rate of 44.1 kHz, so the sound is sampled (recorded) 44,100 times per second. The higher the sampling rate, the higher the sound quality, but also the larger the volume of data.

### Encoding

Converting music CDs, WAVE (AIFF) files, and other sound files into the specified audio compression format.

### Tag

Song information such as track titles, artist names, album names, etc., written into MP3/WMA/AAC files.

### Root folder

The root folder (or root directory) is found at the top of the file system. The root folder contains all folders and files. It is created automatically for all burned discs.

## Sound Setting

### ■ CDE-W265EBT

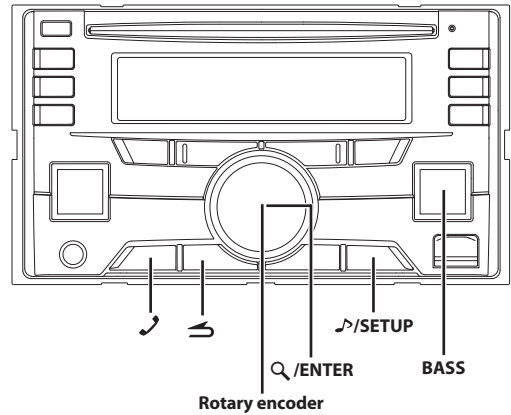

### ■ CDE-164EBT

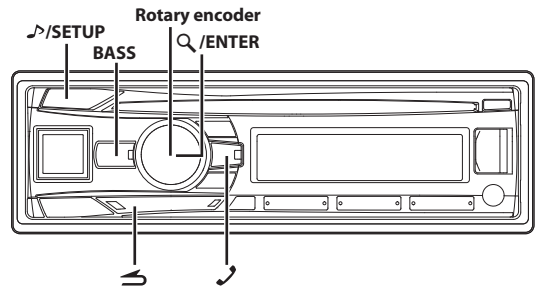

## Adjusting Subwoofer Level/Bass Level/Treble Level/Balance (Between Left and Right)/Fader (Between Front and Rear)/Defeat

### 1 Press ♪/SETUP repeatedly to choose the desired mode.

Each press changes the mode as follows:

SUBWOOFER\*1/\*2 → BASS LEVEL \*2/\*3 → TRE LEVEL \*2/\*3 → BALANCE → FADER\*4 → DEFEAT → VOLUME → SUBWOOFER

\*1 When the subwoofer mode is set to OFF, its level cannot be adjusted, refer to “Turning Subwoofer ON/OFF” on page 17.

\*2 Not displayed when BASS ENGINE SQ mode is selected. Refer to “Switching BASS ENGINE SQ mode” on page 19.

\*3 Adjustable only when DEFEAT is OFF.

\*4 Not displayed when 2WAY/3WAY system mode is set to 3WAY. Refer to “Switching the 2WAY/3WAY system mode” on page 22.

Subwoofer	+0 ~ +15
Bass level	-7 ~ +7
Treble level	-7 ~ +7
Balance	L15 ~ R15
Fader	R15 ~ F15
Defeat	ON/OFF
Volume	0 ~ 35

### Note

- If no operation is performed for 5 seconds, the unit automatically returns to normal mode.

## 2 Turn the Rotary encoder until the desired sound is obtained in each mode.

By setting DEFEAT ON, previously adjusted level settings of BASS and TREBLE will return to the factory defaults.

## Sound Setting

You can flexibly customize the unit to suit your own preference and usage. From the AUDIO SETUP menu, Audio Setting can be modified.

**Use steps 1 to 5 to select the category you wish to modify. For details on how to change each setting, see the following sections below.**

### 1 Press and hold /SETUP for at least 2 seconds to activate the SETUP mode.

### 2 Turn the Rotary encoder to select AUDIO, and then press /ENTER.

### 3 Turn the Rotary encoder to select the desired sound setting menu, and then press /ENTER.

EQ PRESETS<sup>\*1/\*2/\*3</sup> ↔ BASS ENGINE<sup>\*4/\*5</sup> ↔ PARAMETER<sup>\*5/\*6</sup> ↔ 9BAND P-EQ<sup>\*1/\*3/\*7</sup> ↔ SOURCE VOL ↔ X-OVER<sup>\*1/\*3</sup> ↔ SUBWOOFER<sup>\*8</sup> ↔ SUBW PHASE<sup>\*9</sup> ↔ SUBW SYS<sup>\*3/\*9</sup> ↔ LENGTH<sup>\*1</sup> ↔ TCR<sup>\*1</sup> ↔ POWER IC ↔ MX SETTING<sup>\*1/\*3</sup> ↔ EQ PRESETS

- \*1 Adjustment cannot be performed when DEFEAT is set to ON.
- \*2 Any changes made to either EQ PRESETS or 9BAND P-EQ are reflected in the others' settings.
- \*3 These items are not adjustable in BASS ENGINE SQ mode. If you want to adjust these items separately, follow the confirm message and select "YES" to exit BASS ENGINE SQ mode, then make the setting.
- \*4 Not displayed when the Audio Setup mode is activated by pressing BASS.
- \*5 Not displayed when 2WAY /3WAY system mode is set to 3WAY.
- \*6 Not displayed when BASS ENGINE is set to OFF.
- \*7 In step 3, after selecting a Band (BAND1 to BAND9) from 9BAND P-EQ adjustment mode. Turn the **Rotary encoder** to select the desired item, and then press  /ENTER to continue to step 4.
- \*8 This item is also related to BASS ENGINE SQ mode when you adjust sound settings via the TuneIt App on a Smartphone. Refer to "Adjusting the sound via the Smartphone" on page 25.
- \*9 These functions are inoperable when SUBWOOFER is set to OFF.

### 4 Turn the Rotary encoder to change the setting, and then press /ENTER.

(e.g. Select SUBWOOFER ON or SUBWOOFER OFF)

### 5 Press and hold /SETUP for at least 2 seconds to return to normal mode.

### Notes

- Adjustment cannot be performed during a call.
- Pressing  returns to the previous Sound menu mode.
- If no operation is performed for 60 seconds, Sound menu mode is canceled.
- You can access the Sound menu mode directly by pressing BASS when BASS ENGINE is set to OFF. Refer to "Setting BASS ENGINE SQ ON/OFF" on page 16.

## Equalizer Presets

10 typical equalizer settings are preset at the factory for a variety of musical source material. USER settings are created in the 9BAND P-EQ mode.

USER ↔ FLAT (Initial setting) ↔ POPS ↔ ROCK ↔ NEWS ↔ JAZZ ↔ ELEC DANCE ↔ HIP HOP ↔ EASY LIS ↔ COUNTRY ↔ CLASSICAL

### Note

- The 9-Band, Parametric EQ is used to customize the EQ PRESETS settings.

## Setting BASS ENGINE SQ ON/OFF

This function provides a short cut for BASS ENGINE SQ setting. EQ PRESETS, 9BAND P-EQ, etc., will no longer be adjustable when ON is set.

### Setting item: BASS ENGINE

#### Setting contents:

OFF (Initial setting) / ON

#### OFF (MANUAL SET mode):

Adjust each audio effect setting separately.

#### ON (BASS ENGINE SQ mode):

Adjust BASS ENGINE SQ via a short cut.

### Note

- You can also set BASS ENGINE SQ ON/OFF directly by pressing and holding BASS. Refer to "Switching BASS ENGINE SQ mode" on page 19.

## Displaying the BASS ENGINE SQ PARAMETER

After setting BASS ENGINE to ON, you can display the current BASS ENGINE SQ Parameter type.

### Setting item: PARAMETER

#### Displaying contents:

The name of the parameter currently selected is displayed. (INITIAL / TUNEIT A ~ TUNEIT E)

## Adjusting the Parametric Equalizer Curve (9BAND P-EQ)

You can modify the Equalizer settings to create a response curve more appealing to your personal taste.

### 1 After selecting a BAND (BAND1 ~ BAND9) from the 9BAND P-EQ adjustment mode, turn the Rotary encoder to select the desired setting item, and then press /ENTER.

CENTER FRQ ↔ WIDTH (Q) ↔ LEVEL ↔ CENTER FRQ

### 2 Turn the Rotary encoder to select the desired setting value, and then press /ENTER.

### 3 Press to return to the previous step.

## Adjusting the Frequency (CENTER FRQ)

### Adjustable frequency bands: 20 Hz to 20 kHz

Band1	20 Hz ~ 100 Hz (63 Hz)
Band2	63 Hz ~ 315 Hz (125 Hz)
Band3	125 Hz ~ 500 Hz (250 Hz)
Band4	250 Hz ~ 1 kHz (500 Hz)
Band5	500 Hz ~ 2 kHz (1 kHz)
Band6	1 kHz ~ 4 kHz (2 kHz)
Band7	2 kHz ~ 7.2 kHz (4 kHz)
Band8	5.8 kHz ~ 12 kHz (8 kHz)
Band9	9 kHz ~ 20 kHz (16 kHz)

## Setting the Bandwidth (WIDTH (Q))

### Setting contents:

3.0 (Initial setting) / 4.0 / 5.0

## Adjusting the Level (LEVEL)

### Setting contents:

-7 to +7 (Initial setting: ±0)

### Notes

- BAND2 and BAND8 are the same as the Bass and Treble controls. Their Level adjustment can also be controlled by pressing  /SETUP and selecting Bass Level or Treble Level. Refer to "Adjusting Subwoofer Level/Bass Level/Treble Level/Balance (Between Left and Right)/Fader (Between Front and Rear)/Defeat" on page 15.
- Settings exceeding the frequency of adjacent bands are not available.
- While adjusting the 9BAND P-EQ, you should consider the frequency response of the connected speakers.
- The 9-Band, Parametric EQ is used to customize the EQ PRESETS settings.

## Setting the Source Volume Level

The output level of each source is individually adjustable. For example, if the TUNER level sounds lower than CD, its output can be adjusted without affecting the other sources.

### Setting item: SOURCE VOL

### Further setting items: TUNER / DISC / USB / IPOD / BT AUDIO / PANDORA / AUX

### Setting contents:

-14 dB ~ +14 dB (Initial setting: ±0)

## Adjusting the Crossover Settings (X-OVER)

Before performing the following procedures, refer to "About the Crossover" on page 21.

### Setting item: X-OVER

1 Turn the Rotary encoder to select the channel, and then press  /ENTER.

### 2WAY System

FRONT (HPF) ↔ REAR (HPF) ↔ SUBW LPF ↔ FRONT (HPF)

### 3WAY System

LOW (LPF) ↔ MID LOW (HPF) ↔ MID HIGH (LPF) ↔ HIGH (HPF) ↔ LOW

2 Turn the Rotary encoder to select the desired item, and then press  /ENTER.

## Selecting the Cut-Off Frequency (FREQUENCY)

### 2WAY System

#### Setting contents:

20 / 25 / 31.5 / 40 / 50 / 63 / 80 (Initial setting) / 100 / 125 / 160 / 200 (Hz)

### 3WAY System

#### Setting contents:

##### LOW/MID LOW:

20 / 25 / 31.5 / 40 / 50 / 63 / 80 / 100 / 125 / 160 / 200 / 250 / 315 / 400 / 500 (Initial setting) / 630 / 800 (Hz)

##### MID HIGH:

20 / 25 / 31.5 / 40 / 50 / 63 / 80 / 100 / 125 / 160 / 200 / 250 / 315 / 400 / 500 / 630 / 800 / 1 k / 1.2 k / 1.6 k / 2 k / 2.5 k / 3.2 k / 4 k / 5 k (Initial setting) / 6.3 k / 8 k / 10 k / 12.5 k / 16 k / 20 k (Hz)

##### HIGH:

1 k / 1.2 k / 1.6 k / 2 k / 2.5 k / 3.2 k / 4 k / 5 k (Initial setting) / 6.3 k / 8 k / 10 k / 12.5 k / 16 k / 20 k (Hz)

### Note

- The frequency of MID LOW should not be more than the frequency of MID HIGH.

## Adjusting the Slope (SLOPE)

### 2WAY System

#### Setting contents:

FLAT / 6 / 12 / 18 / 24 (dB/oct.)

### 3WAY System

#### Setting contents:

FLAT / 6 / 12 (dB/oct.)

### Note

- The Initial setting of 2WAY is FLAT, 3WAY is 12.

## Adjusting the Level (LEVEL)

### 2WAY System/3WAY System

#### Setting contents:

-12 to 0 (dB) (Initial setting: 0)

### Note

- The level setting results of MID LOW and MID HIGH in 3WAY system are linkage.

3 Repeat steps 1 to 2 to make adjustment to the other channels.

## Turning Subwoofer ON/OFF

When the subwoofer is on, you can adjust the subwoofer output level (refer to "Adjusting Subwoofer Level/Bass Level/Treble Level/Balance (Between Left and Right)/Fader (Between Front and Rear)/Defeat" on page 15).

### Setting item: SUBWOOFER

#### Setting contents:

OFF / ON (Initial setting)

##### OFF:

No subwoofer signal is output from the Subwoofer RCA Connectors (refer to "Connections" on page 50).

##### ON:

The subwoofer signal is output from the Subwoofer RCA Connectors (refer to "Connections" on page 50).

## Setting the Subwoofer Phase

The subwoofer output phase is toggled between SUBWOOFER NORMAL (0°) or SUBWOOFER REVERSE (180°). Depending on the installation location of your subwoofer, one of these settings may sound better than the other.

### Setting item: SUBW PHASE

#### Setting contents:

NORMAL (Initial setting) / REVERSE

## Setting the Subwoofer System

When the subwoofer is on, you can select either SYSTEM 1 or SYSTEM 2 for the desired subwoofer effect.

### Setting item: SUBW SYS

#### Setting contents:

SYSTEM 1 / SYSTEM 2 (Initial setting)

#### SYSTEM 1:

Subwoofer level changes according to the main volume setting.

#### SYSTEM 2:

Subwoofer level change is different from the main volume setting. For example, even at low volume settings, the subwoofer is still audible.

## Setting the Time Correction Unit (LENGTH)

You can change the unit of time correction (centimetres or inches).

### Setting item: LENGTH

#### Setting contents:

CM (Initial setting) / INCH

#### CM:

Time correction value is in centimetres.

#### INCH:

Time correction value is in inches.

## Adjusting the Time Correction (TCR)

Before performing the following, refer to “About Time Correction” on page 19.

### 1 Turn the Rotary encoder to select the desired speaker after selecting TCR, and then press **Q** / **ENTER**.

FRONT-L ↔ FRONT-R ↔ REAR-L ↔ REAR-R ↔ SUBW-L ↔ SUBW-R ↔ FRONT-L

### 2 Turn the Rotary encoder to adjust the distance of the selected speaker, and then press **Q** / **ENTER**.

0.0 cm to 336.6 cm (3.4 cm/step)

0.0 inch to 132.7 inch (1.3 inch/step)

#### Note

- The total adjustment distance for all speakers should be less than 510 centimetres (201 inches).

### 3 Repeat steps 1 and 2 for setting other speakers.

By setting these values, sound from all speakers can be made to reach the listener at the same time.

## External Device

### Connecting to an External Amplifier (POWER IC)

When an external amplifier is connected, sound quality can be improved by stopping the power supply of the built-in amplifier.

### Setting item: POWER IC

#### Setting contents:

OFF / ON (Initial setting)

#### OFF:

Use this mode when the line output of this unit is used to drive an external amplifier. In this setting, the head unit's internal amplifier is turned OFF and cannot drive speakers.

#### ON:

The speakers are driven by the built-in amplifier.

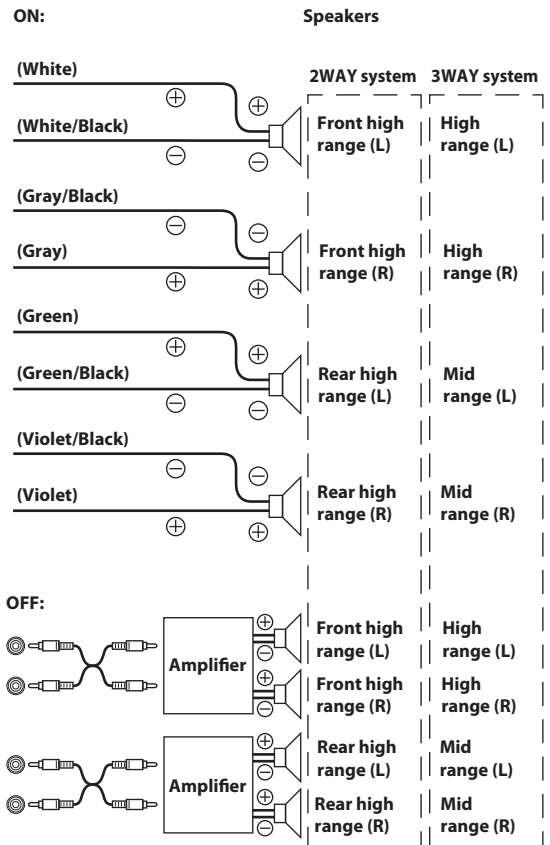

#### Notes

- For more details about 2WAY/3WAY system mode. Please refer to “Switching the 2WAY/3WAY system mode” and “About the 2WAY/3WAY system mode” on page 22.
- No sound is produced by the system when the power output is set to OFF.



## Setting the Media Xpander mode

MX (Media Xpander) makes vocals or instruments sound distinct regardless of the music source. The CD and iPod, etc. will be able to reproduce the music clearly even in cars with a lot of road noise.

### Setting item: MX SETTING

#### 1 Turn the Rotary encoder to select the source to which you want to apply Media Xpander, and then press **Q/ENTER**.

FM ↔ CD ↔ CMPM\* ↔ USB ↔ IPOD ↔ BT AUDIO ↔ PANDORA  
↔ AUX ↔ FM

\* Be applied for MP3/WMA/AAC files in disc.

#### 2 Turn the Rotary encoder to select the Media Xpander level, and then press **Q/ENTER**.

OFF ↔ LEVEL 1 ↔ LEVEL 2 ↔ LEVEL 3

#### Note

- There is no MX mode for AM radio.

## BASS ENGINE SQ Function

With the BASS ENGINE SQ function on this unit, several parameters affecting Bass performance are adjusted simultaneously. The Bass Level adjustment varies these parameters uniformly for optimum Bass effect at different levels.

## Switching BASS ENGINE SQ mode

Press and hold **BASS** for at least 2 seconds to switch the sound mode.

BASS ENGINE SQ ↔ MANUAL SET (Initial setting)

#### BASS ENGINE SQ:

Adjust the relevant Bass parameters uniformly and automatically.

#### MANUAL SET:

Adjust each audio effect setting separately and manually.

#### Notes

- This operation can also be performed by selecting BASS ENGIN in Audio Setup mode. Refer to "Setting BASS ENGINE SQ ON/OFF" on page 16.
- You can access the Sound menu directly by pressing **BASS** when BASS ENGIN is set to OFF.
- You can set this item via the TuneIt App on a Smartphone. Refer to "Adjusting the sound via the Smartphone" on page 25.
- If you switch the 2WAY/3WAY system (page 22) to 3WAY mode, you cannot adjust this item.

## Adjusting BASS ENGINE SQ Level

With BASS ENGINE SQ ON, adjusting the Bass Level uniformly effects various sound parameters for optimum Bass effect.

#### 1 Press **BASS** to display the BASS ENGINE SQ Level adjustment screen.

The unit's back lighting changes to white amber during this period.

#### 2 Turn the Rotary encoder to select the desired level (+0 - +6).

The initial level is +3.

#### Notes

- Adjustable only when DEFEAT is OFF.
- Adjustable when 2WAY/3WAY system mode is set to 2WAY.
- The Bass parameters affected contain EQ PRESETS, 9BAND EQ, SUBWOOFER (when set this item via TuneIt App), X-OVER, SUBSYS and MX SETTING. These items are set automatically in BASS ENGINE SQ mode and cannot be adjusted separately.
- From Level 0 to Level 6, the effect of BASS ENGINE SQ Enhance increases level by level.
- If no operation is performed for 5 seconds, the unit automatically returns to normal mode.

#### About Setup when the external power amplifier is connected.

In order to optimize the BASS ENGINE SQ, we recommend the following power amplifier setup.

After setting up, you can adjust the BASS ENGINE SQ Level according to the music.

- 1 Set gain of the power amplifier to "MIN".
- 2 Set the Crossover Mode Sector switch to "OFF".
- 3 Set the BASS ENGINE SQ of this unit to "ON", and the BASS ENGINE SQ Level to "+3".
- 4 Play a song of the genre you frequently listen to, and adjust gain of the power amplifier.

## About Time Correction

The distance between the listener and the speakers in a car vary widely due to the complex speaker placement. This difference in the distances from the speakers to the listener creates a shift in the sounds image and frequency characteristics. This is caused by the time delay between the sound reaching the listener's right versus the left ear.

To correct this, this unit is able to delay the audio signal to the speakers closest to the listener. This effectively creates a perception of increased distance for those speakers. The listener can be placed at an equal distance between the left and right speakers for optimum staging. The adjustment will be made for each speaker in 3.4cm steps.

### Example 1. Listening Position: Front Left Seat

Adjust the time correction level of the front left speaker to a high value and the rear right to zero or a low value.

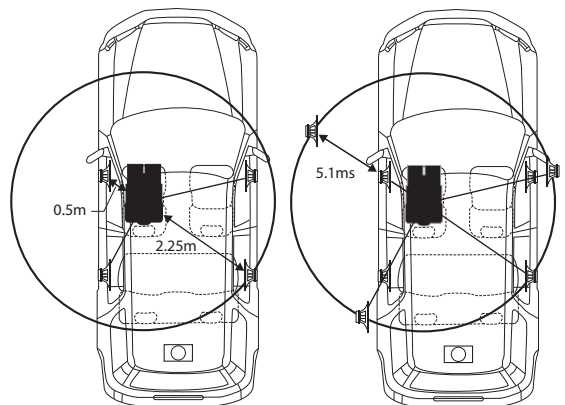

The sound is not balanced because the distance between the listening position and the various speakers is different.

The difference in distance between the front left speaker and the rear right speaker is 1.75 m (68-7/8").

Here we calculate the time correction value for the front left speaker in the diagram on the above.

**Conditions:**

Farthest Speaker – listening position: 2.25 m (88-9/16")

Front left speaker – listening position: 0.5 m (19-11/16")

Calculation:  $L = 2.25 \text{ m} - 0.5 \text{ m} = 1.75 \text{ m}$  (68-7/8")

Time correction =  $1.75 \div 343^* \times 1,000 = 5.1 \text{ (ms)}$

\* Speed of sound: 343 m/s (765 mph) at 20°C

In other words, giving the front left speaker a time correction value of 5.1 ms makes it seem as if its distance from the listener is the same as the distance to the farthest speaker.

Time correction eliminates the differences in the time required for the sound to reach the listening position.

The time of the front left speaker is corrected by 5.1 ms so that its sound reaches the listening position at the same time as the sound of other speakers.

**Example 2. Listening Position: All Seats**

Adjust the time correction level of each speaker to almost the same level.

**1** Sit in the listening position (driver's seat, etc.) and measure the distance (in metres) between your head and the various speakers.

**2** Calculate the difference between the distance correction value to the farthest speaker and the other speakers.

$L = (\text{distance to farthest speaker}) - (\text{distance to other speakers})$

These values are the time correction values for the different speakers. Setting these values to make each sound reach the listening position at the same time as the sound of other speakers.

**Time Correction Value List**

Delay Number	Time Difference (msec)	Distance (cm)	Distance (inch)
0	0.0	0.0	0.0
1	0.1	3.4	1.3
2	0.2	6.8	2.7
3	0.3	10.2	4.0
4	0.4	13.6	5.4
5	0.5	17.0	6.7
6	0.6	20.4	8.0
7	0.7	23.8	9.4
8	0.8	27.2	10.7
9	0.9	30.6	12.1
10	1.0	34.0	13.4
11	1.1	37.4	14.7
12	1.2	40.8	16.1
13	1.3	44.2	17.4
14	1.4	47.6	18.8
15	1.5	51.0	20.1
16	1.6	54.4	21.4
17	1.7	57.8	22.8
18	1.8	61.2	24.1
19	1.9	64.6	25.5
20	2.0	68.0	26.8
21	2.1	71.4	28.1
22	2.2	74.8	29.5
23	2.3	78.2	30.8
24	2.4	81.6	32.2

Delay Number	Time Difference (msec)	Distance (cm)	Distance (inch)
25	2.5	85.0	33.5
26	2.6	88.4	34.8
27	2.7	91.8	36.2
28	2.8	95.2	37.5
29	2.9	98.6	38.9
30	3.0	102.0	40.2
31	3.1	105.4	41.5
32	3.2	108.8	42.9
33	3.3	112.2	44.2
34	3.4	115.6	45.6
35	3.5	119.0	46.9
36	3.6	122.4	48.2
37	3.7	125.8	49.6
38	3.8	129.2	50.9
39	3.9	132.6	52.3
40	4.0	136.0	53.6
41	4.1	139.4	54.9
42	4.2	142.8	56.3
43	4.3	146.2	57.6
44	4.4	149.6	59.0
45	4.5	153.0	60.3
46	4.6	156.4	61.6
47	4.7	159.8	63.0
48	4.8	163.2	64.3
49	4.9	166.6	65.7
50	5.0	170.0	67.0
51	5.1	173.4	68.3
52	5.2	176.8	69.7
53	5.3	180.2	71.0
54	5.4	183.6	72.4
55	5.5	187.0	73.7
56	5.6	190.4	75.0
57	5.7	193.8	76.4
58	5.8	197.2	77.7
59	5.9	200.6	79.1
60	6.0	204.0	80.4
61	6.1	207.4	81.7
62	6.2	210.8	83.1
63	6.3	214.2	84.4
64	6.4	217.6	85.8
65	6.5	221.0	87.1
66	6.6	224.4	88.4
67	6.7	227.8	89.8
68	6.8	231.2	91.1
69	6.9	234.6	92.5
70	7.0	238.0	93.8
71	7.1	241.4	95.1
72	7.2	244.8	96.5
73	7.3	248.2	97.8
74	7.4	251.6	99.2

Delay Number	Time Difference (msec)	Distance (cm)	Distance (inch)
75	7.5	255.0	100.5
76	7.6	258.4	101.8
77	7.7	261.8	103.2
78	7.8	265.2	104.5
79	7.9	268.6	105.9
80	8.0	272.0	107.2
81	8.1	275.4	108.5
82	8.2	278.8	109.9
83	8.3	282.2	111.2
84	8.4	285.6	112.6
85	8.5	289.0	113.9
86	8.6	292.4	115.2
87	8.7	295.8	116.6
88	8.8	299.2	117.9
89	8.9	302.6	119.3
90	9.0	306.0	120.6
91	9.1	309.4	121.9
92	9.2	312.8	123.3
93	9.3	316.2	124.6
94	9.4	319.6	126.0
95	9.5	323.0	127.3
96	9.6	326.4	128.6
97	9.7	329.8	130.0
98	9.8	333.2	131.3
99	9.9	336.6	132.7

## About the Crossover

### Crossover (X-OVER):

This unit is equipped with an active crossover. The crossover limits the frequencies delivered to the outputs. Each channel is controlled independently. Thus, each speaker pair can be driven by the frequencies for which they have been optimally designed. The crossover adjusts the HPF (high pass filter) or LPF (low pass filter) of each band, and also the slope (how fast the filter rolls off the highs or lows).

Adjustments should be made according to the reproduction characteristics of the speakers. Depending on the speakers, a passive network may not be necessary. If you are unsure about this point, please consult your authorized Alpine dealer.

### 2WAY mode

	Cut-off frequency (1/3 octave steps)		Slope		Level
	HPF	LPF	HPF	LPF	
<b>Low range speaker</b>	---	20 Hz - 200 Hz	---	FLAT, 6, 12, 18, 24 dB/oct.	0 to -12 dB
<b>Rear high range speaker</b>	20 Hz - 200 Hz	---	FLAT, 6, 12, 18, 24 dB/oct.	---	0 to -12 dB
<b>Front high range speaker</b>	20 Hz - 200 Hz	---	FLAT, 6, 12, 18, 24 dB/oct.	---	0 to -12 dB

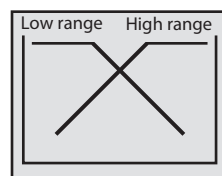

(Different from actual display)

### 3WAY mode

	Cut-off frequency (1/3 octave steps)		Slope		Level
	HPF	LPF	HPF	LPF	
<b>Low range speaker</b>	---	20 Hz - 800 Hz	---	FLAT, 6, 12 dB/oct.	0 to -12 dB
<b>Mid range speaker</b>	20 Hz - 800 Hz	20 Hz - 20 kHz	FLAT, 6, 12 dB/oct.	FLAT, 6, 12 dB/oct.	0 to -12 dB
<b>High range speaker</b>	1 kHz - 20 kHz*	---	FLAT, 6, 12 dB/oct.	---	0 to -12 dB

\* Depending on the response characteristics of the speaker, care should be taken when setting the response slope of the high range speaker to FLAT in 3WAY mode, as speaker damage may result (page 22).

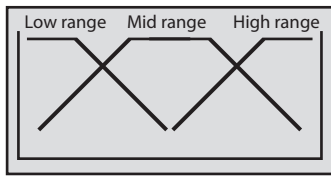

(Different from actual display)

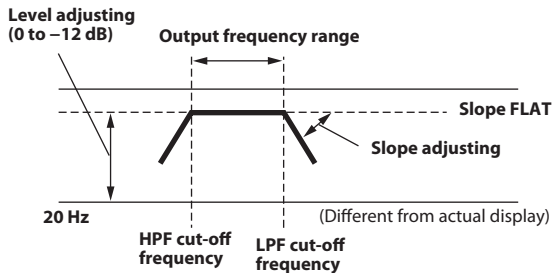

### Notes

- **HPF (high pass filter):** Cuts the lower frequencies and allows the higher frequencies to pass.
  - **LPF (low pass filter):** Cuts the higher frequencies and allows the lower frequencies to pass.
  - **Slope:** The level change (in dB) for a frequency change of one octave.
  - The higher the slope value, the steeper the slope becomes.
  - Adjust the slope to **FLAT** to bypass the HP or LP filters.
  - Do not use a tweeter without the HPF on or set to a low frequency, as it may cause damage to the speaker due to the low frequency content.
  - You cannot adjust the crossover frequency higher than the HPF or lower than the LPF.
  - Adjustment should be made according to the recommended crossover frequency of the connected speakers. Determine the recommended crossover frequency of the speakers. Adjusting to a frequency range outside that recommended may cause damage to the speakers. For the recommended crossover frequencies of Alpine speakers, refer to the respective Owner's Manual.
- We are not responsible for damage or malfunction of speakers caused by using the crossover outside the recommended value.

### Switching the 2WAY/3WAY system mode

- 1 Press the **🎵 / SETUP** and **🔍** at the same time.

#### Note

- In this case, the device will be muted.

- 2 Turn the **Rotary encoder** to select the desired system mode, and then press **🔍 / ENTER**.

#### Note

- When the system mode is changed, the setting items for X-OVER are displayed. Please follow the instructions of "Adjusting the Crossover Settings (X-OVER)" on page 17 to made the setting.

- 3 After setting, turn the **Rotary encoder** to select **DONE**, and then press **🔍 / ENTER**.

"TURN ACC OFF AND ON" will be displayed.

- 4 Switch the **ignition key to ACC OFF**.

Depending on the response characteristics of the speaker, care should be taken when you switch the 2WAY/3WAY system, as speaker damage may result.

- 5 Switching the **ignition key from ACC OFF to ON**.

The change is saved.

#### Notes

- If you skip the 4th and the 5th steps, the setting results will not be saved and unit will return to previous mode.
- While playing back music after the vehicle's ignition is turned off (STAY ON mode), you cannot adjust the 2WAY/3WAY mode (refer to "Setting the stay on mode" on page 27).

### About the 2WAY/3WAY system mode

The X-OVER for a 2WAY system (frequency range is divided between highs for front/rear and lows for the Subwoofer).

#### 2WAY mode

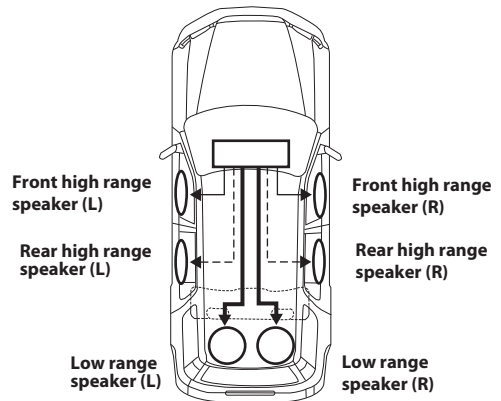

The X-OVER for a 3WAY system whose frequency range is divided among the highs (Front), mids (Front), and lows (Subwoofer).

#### 3WAY mode

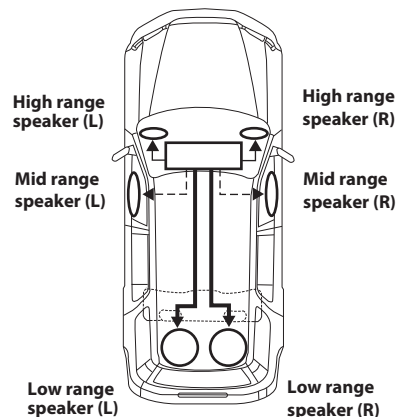

#### Output of this unit:

- Front output
- - - Rear output
- SUB-W output

- Use the Sub-W output cord to connect the unit to the low range speaker.
- You cannot adjust the fader when set to 3WAY.

# Other Functions

## ■ CDE-W265EBT

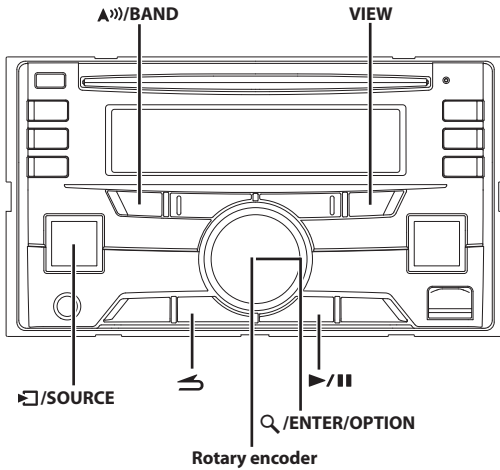

## ■ CDE-164EBT

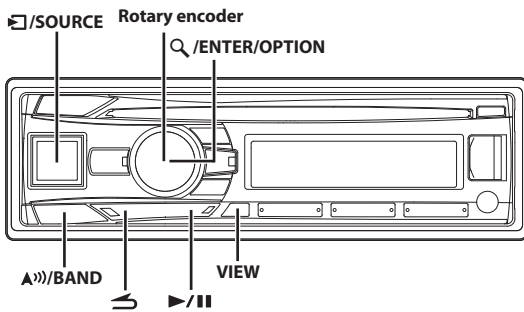

## Displaying the Text

Text information, such as the disc name and the track name, will be displayed if playing a CD text compatible disc. It is also possible to display the folder name, the file name and the tag, etc., while playing MP3/WMA/AAC files.

### Press **VIEW**.

The display will change every time the button is pressed.

### Note

- When the TEXTSCROLL is set to MANUAL, press and hold **VIEW** for at least 2 seconds, the current text will be scrolled one time (except Radio mode).

### The display in Radio mode:

BAND/FREQUENCY → BAND/CLOCK → BAND/FREQUENCY

### The display in CD mode:

TRACK NO./ELAPSED TIME → DISC TEXT<sup>\*1</sup>/TRACK TEXT<sup>\*1</sup> → TRACK NO./CLOCK → TRACK NO./ELAPSED TIME

### The display in MP3/WMA/AAC mode:

FOLDER NO./FILE NO./ELAPSED TIME → FOLDER NAME<sup>\*2</sup>/FILE NAME<sup>\*2</sup> → ARTIST NAME<sup>\*3</sup>/SONG NAME<sup>\*3</sup> → ALBUM NAME<sup>\*3</sup>/SONG NAME<sup>\*3</sup> → FOLDER NO./FILE NO./CLOCK → FOLDER NO./FILE NO./ELAPSED TIME

### The display in Bluetooth Audio mode:

BT AUDIO/ELAPSED TIME<sup>\*4</sup> → ARTIST NAME<sup>\*3</sup>/SONG NAME<sup>\*3</sup> → ALBUM NAME<sup>\*3</sup>/SONG NAME<sup>\*3</sup> → BT AUDIO/CLOCK → BT AUDIO/ELAPSED TIME

- \*1 Displayed during playback of a disc with CD text. If there is no Text (Disc Name or Track Name), "DISC TEXT"/"TRACK TEXT" is displayed.
- \*2 Displayed during playback of MP3/WMA/AAC with folder/file information. If there is no folder/file information, "FOLDER"/"FILE" is displayed.
- \*3 ID3 tag/WMA tag  
If an MP3/WMA/AAC file contains ID3 tag/WMA tag information, the ID3 tag/WMA tag information is displayed (e.g., song name, artist name, and album name). All other tag data is ignored.  
If there is no tag information, "ARTIST"/"ALBUM"/"SONG" is displayed.
- \*4 Depending on the connected Smartphone, the elapsed time may not be displayed.

## About "Text"

Text compatible CDs contain text information such as the disc name and track name. Such text information is referred to as "text".

### Notes

- Some characters may not be displayed correctly with this device, depending on the character type.
- "NO SUPPORT" is displayed when the desired text information cannot be displayed on this unit.
- The text or tag information may not be correctly displayed, depending on the contents.

## Using the Front AUX Input Terminal

Connect a portable music player, etc. by simply connecting it to the input on the front panel. An optional adapter cable is required (standard RCA to 3.5ø mini-phono plug or 3.5ø to 3.5ø mini-phono plug).

Press **<math>\square</math>/SOURCE**, and select the AUXILIARY mode to listen to the portable device.

### ■ CDE-W265EBT

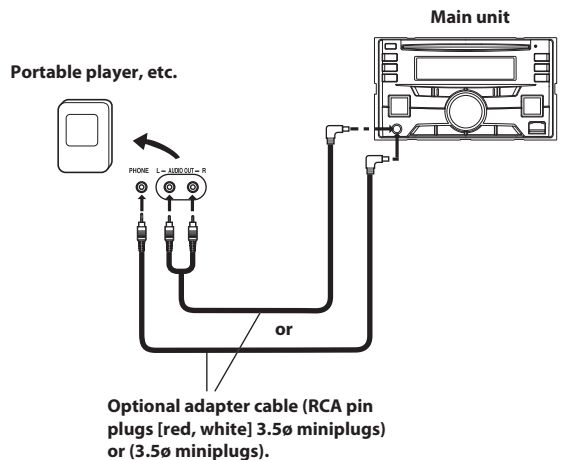

Optional adapter cable (RCA pin plugs [red, white] 3.5ø miniplugs or 3.5ø miniplugs).

## CDE-164EBT

Portable player, etc.

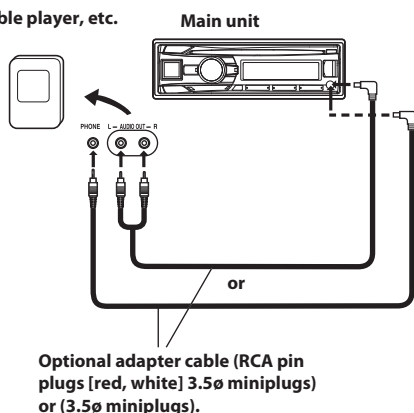

### Note

- This function is available only when AUX SETUP is set to ON. For details, refer to "Setting the AUX SETUP mode" on page 26.

## Option Menu Setting

You can quickly adjust the setting items relevant to the current SOURCE by using Option Menu.

- Press and hold **Q** /ENTER/OPTION for at least 2 seconds to activate the Option menu of the current source.

### Note

- The option menu varies depending on the source.

- Turn the Rotary encoder to select the desired setting item, and then press **Q** /ENTER.
- Turn the Rotary encoder to change the setting, and then press **Q** /ENTER.

After the setting, the display will return to the current source automatically.

### Setting item:

#### TUNER mode:

TUNER SET\*<sup>1</sup> ↔ SOURCE VOL\*<sup>2</sup> ↔ MX SETTING\*<sup>3</sup> ↔ TUNER SET

#### DISC mode:

CD SET\*<sup>4</sup> ↔ SOURCE VOL\*<sup>2</sup> ↔ MX SETTING\*<sup>3</sup> ↔ CD SET

#### USB mode:

SOURCE VOL\*<sup>2</sup> ↔ MX SETTING\*<sup>3</sup> ↔ SOURCE VOL

#### iPod mode:

APP DIRECT\*<sup>5</sup> ↔ IPOD SET\*<sup>6</sup> ↔ SOURCE VOL\*<sup>2</sup> ↔ MX SETTING\*<sup>3</sup> ↔ APP DIRECT

#### AUX mode:

AUX SET\*<sup>7</sup> ↔ SOURCE VOL\*<sup>2</sup> ↔ MX SETTING\*<sup>3</sup> ↔ AUX SET

#### Pandora mode:

SOURCE VOL\*<sup>2</sup> ↔ MX SETTING\*<sup>3</sup> ↔ SOURCE VOL

#### BT AUDIO mode:

BT SET\*<sup>8</sup> ↔ SOURCE VOL\*<sup>2</sup> ↔ MX SETTING\*<sup>3</sup> ↔ BT SET

#### Phone mode (Non-calling mode):

PHONE SET\*<sup>9</sup> ↔ SOURCE VOL\*<sup>10</sup> ↔ PHONE SET

#### Phone mode (Calling mode):

MIC GAIN\*<sup>11</sup> ↔ CALL SOUND\*<sup>12</sup> ↔ SPK SWITCH\*<sup>13</sup> ↔ VOICE MUTE\*<sup>14</sup> ↔ CALL WAIT\*<sup>15</sup> ↔ END CALL\*<sup>16</sup> ↔ SOURCE VOL\*<sup>10</sup> ↔ MIC GAIN

- \*1 The setting items are the same as TUNER setting in SETUP mode. For details, refer to "SETUP" on page 26.
- \*2 You can individually emphasize or weaken the volume level of the current source to create your own tonal preference. The setting values in Option mode and in SETUP mode are linked. Refer to "Setting the Source Volume Level" on page 17.
- \*3 Refer to "Setting the Media Xpander mode" on page 19.
- \*4 PLAY MODE can be selected in this mode. For details, refer to "Playing MP3/WMA/AAC Data (PLAY MODE)" on page 27.
- \*5 Refer to "Setting the iPod Control" on page 37.
- \*6 The setting items are the same as iPod setting in SETUP mode. For details, refer to "iPod/iPhone Search Mode Setting" on page 28.
- \*7 AUX NAME can be selected in this mode. For details, refer to "Setting the AUX NAME mode" on page 27.
- \*8 FW VERSION can be selected in this mode. You can see the current firmware version about Bluetooth by using this setting.
- \*9 CALL SOUND, CALLER ID, PB UPDATE, PB ORDER, SPEAKER SL and FW VERSION can be selected in this mode. For details about these settings, refer to "Bluetooth SETUP" on page 30.
- \*10 The Hands free phone talk level, ring tone level and microphone gain level can be adjusted by using this setting. The setting values in Option mode and in SETUP mode are linked. Refer to "Adjusting the volume (SOURCE VOL)" on page 31.
- \*11 Refer to "Setting the Bluetooth sound quality" on page 31.
- \*12 While calling, the call sound can be switched between the unit and Smartphone by using this setting. This operation can also be done by pressing **▲** /BAND. Refer to "Call Switching Operation" on page 34.
- \*13 While calling, and the Voice Mute is activated, the microphone input will mute instantly and "VOICE MUTE" will blink. This operation can also be done by pressing **▶** /II. Refer to "Muting the microphone input quickly (Voice Mute)" on page 34.
- \*14 If there is a waiting call, select this item to display the waiting person Name and number. Press **VIEW** to switch the information between the current call and the person on hold.
- \*15 Select this item to hang up the call.

### Notes

- Press **↶** to return to the previous mode.
- If no operation is performed for 60 seconds, the unit will return to normal mode automatically.

## Applying TuneIt

This unit's sound tuning is programmable from a connected Smartphone. It is also possible to download specific parameters for certain vehicles from Alpine's TuneIt database stored in the Cloud. Using the TuneIt App, customized parameters can also be uploaded for others to share and rate.

Through this unit, it is also possible to receive and respond to information from Alpine's Social Network Service (SNS) available through the connected Smartphone.

The installed TuneIt App should be launched on the Smartphone before connection to the head unit.

TuneIt, is downloadable from Apple's App Store; the Android user can download it from Google Play. For details, consult your Alpine dealer. Before these operations, set ALPINE APP to USB or BT depending on the connected Smartphone. For details, refer to "Setting the communication mode with a Smartphone (ALPINE APP)" on page 28.

### Notes

- The application program and related specifications and data may be deleted or terminated without notice.

- Some TuneIt functions may not be available if the Smartphone is not in a service area or receives no signal.

## Adjusting the sound via the Smartphone

After setting the above procedure, the  indicator lights up, and then you can adjust the unit's sound function on the Smartphone.

- 1 **Make sure the unit is powered on.**
- 2 **Launch the TuneIt App on the Smartphone. Adjust the unit's sound accordingly on the Smartphone.**  
During sound setting, the  indicator may blink.

### Notes

- Volume level cannot be adjusted via the Smartphone.
- The setting cannot be done on both the Smartphone and this unit at the same time. While the sound function of this unit is set via the Smartphone, sound function settings on CDE-W265EBT/CDE-164EBT will be displayed as "APPCONNECT".
- In some situations, such as the unit is powered off, during a call etc., sound setting cannot be done via the Smartphone.
- This function may not be available depending on the paired Smartphone.
- Please obey all local traffic laws while using this function.

## Facebook Notification Function



Some functions may be available in a future version of TuneIt.

### Note

- Depending on the paired Smartphone, the following functions may not be available even though the TuneIt version is updated.

## Receiving Notification

When the Smartphone connected to this unit receives notification from Facebook, the unit's back lighting and the  indicator blinks (depending on the TuneIt settings on the phone). At the same time, the user's name is shown in the display (20 characters maximum). Play back the notification via TTS (Text To Speech) by the following procedure.

- 1 **While receiving Notification from Facebook, press  /SOURCE button.**  
Notification Menu screen is displayed.
- 2 **Turn the Rotary encoder to select the desired mode, and then press  /ENTER.**

LIKE\*1 ↔ REPLAY ↔ NEXT ↔ PREVIOUS ↔ TTS VOLUME\*2

\*1 Not displayed when the received Notification is Message type.

\*2 It can also be set in SETUP section. For details, refer to "Setting the TTS (Text To Speech) volume" on page 28.

<b>LIKE:</b>	The Smartphone feedbacks to Facebook with "Like", and meanwhile, the received Wall Posts or Comments are played back by TTS (Text To Speech).
<b>REPLAY:</b>	To play back Notification by TTS (Text To Speech) again.
<b>NEXT:</b>	To select the next Notification.
<b>PREVIOUS:</b>	To select the previous Notification.
<b>TTS VOLUME:</b>	To adjust the playback volume of TTS (Text To Speech).



### Notes

- Press  to return to the previous mode.
- A new received Notification prompt will last for 30 seconds. If there is no operation within 30 seconds, the unit will return to normal mode.
- In some situations, such as the unit is powered off or during a call etc., notification of the Smartphone will not be prompted by this unit.

- In 3WAY mode, the TTS sound is output from all of speaker in car. In 2WAY mode, the TTS sound is only output from Front Left/Right speaker.

## Displaying Notification List

You can view the received Notification from Facebook in the connected Smartphone via this unit.

- 1 **Press and hold  /SOURCE for at least 2 seconds.**  
The received Notification will be displayed according to when it was posted.
- 2 **Turn the Rotary encoder to select the desired Notification, and then press  /ENTER.**
- 3 **Then go to step 2 of "Receiving Notification".**

### Notes

- When there is no Notification, "NO NOTIF" will be displayed.
- The displayable amount of the Notification list depends on the connected Smartphone.
- If no operation is performed for 60 seconds, the unit will return to normal mode automatically.

# SETUP

## CDE-W265EBT

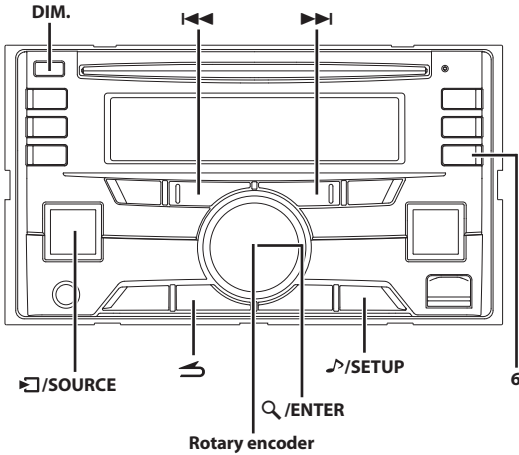

## CDE-164EBT

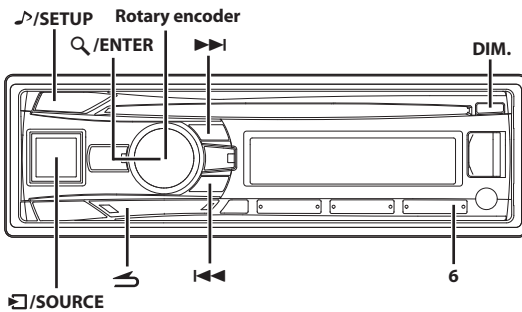

## Setting

You can flexibly customize the unit to suit your own preferences and usage. From the SETUP menu, GENERAL Setting, DISPLAY Setting, etc., can be modified.

**Use steps 1 to 5 to select one of the SETUP modes to modify. See the applicable section below for details about the selected SETUP item.**

- 1** Press and hold  $\curvearrowright$ /SETUP for at least 2 seconds to activate the SETUP mode.
- 2** Turn the Rotary encoder to select the desired item, and then press Q/ENTER.  
 AUDIO\*1  $\leftrightarrow$  GENERAL  $\leftrightarrow$  DISPLAY  $\leftrightarrow$  TUNER  $\leftrightarrow$  IPOD  $\leftrightarrow$  APP  $\leftrightarrow$  BLUETOOTH\*2  $\leftrightarrow$  AUDIO  
 (e.g. Select GENERAL)  
**GENERAL:**  
 CLOCK MODE  $\leftrightarrow$  CLOCK ADJ\*3  $\leftrightarrow$  PWR CLOCK  $\leftrightarrow$  AUX SETUP  $\leftrightarrow$  AUX NAME\*4  $\leftrightarrow$  PLAY MODE  $\leftrightarrow$  STAY ON  $\leftrightarrow$  DEMO MODE  $\leftrightarrow$  CLOCK MODE  
**DISPLAY:**  
 ILLUMINATI  $\leftrightarrow$  DIMMER  $\leftrightarrow$  TEXTSCROLL  $\leftrightarrow$  SCROLLTYPE  $\leftrightarrow$  ILLUMINATI

- TUNER:**  
 FM SET  
**IPOD:**  
 IPOD LIST  
**APP:**  
 ALPINE APP  $\leftrightarrow$  TTS VOLUME  $\leftrightarrow$  ALPINE APP

- \*1 Refer to "Sound Setting" on page 16.  
 \*2 Refer to "Bluetooth SETUP" on page 30.  
 \*3 Refer to "Setting Time" on page 10.  
 \*4 Displayed only when AUX SETUP is set to ON.

- 3** Select an Item with the Rotary encoder, and then press Q/ENTER.  
 (e.g. Select AUX SETUP)
- 4** Turn the Rotary encoder to change the setting, and then press Q/ENTER.  
 (e.g. Select ON or OFF)
- 5** Press and hold  $\curvearrowright$ /SETUP for at least 2 seconds to return to normal mode.

### Notes

- Press  $\curvearrowleft$  to return to the previous mode.
- If no operation is performed for 60 seconds, the unit will return to normal mode automatically.

## General Setting

GENERAL is selected on the setup main menu in step 2.

### Setting the Clock Display (CLOCK MODE)

You can select the clock display type, 12-hour or 24-hour, depending on your preference.

**Setting item:** CLOCK MODE

**Setting contents:**  
 12H (Initial setting) / 24H

### Turning the Clock Display ON/OFF

**Setting item:** PWR CLOCK

**Setting contents:**  
 OFF / ON (Initial setting)

**OFF:**  
 The clock isn't displayed when the power is off.

**ON:**  
 The clock is displayed when the power is off.

### Setting the AUX SETUP mode

You can input the audio of an external device, (such as a Portable audio player) to the AUX connector of this unit.

**Setting item:** AUX SETUP

**Setting contents:**  
 OFF / ON (Initial setting)

**OFF:**  
 When set to OFF, AUX source cannot be selected.

**ON:**  
 Set to ON when a portable device is connected. If  $\square$ /SOURCE is pressed and AUX is selected, the sound of the portable device is input to the unit.



## Setting the AUX NAME mode

You can change the AUX NAME display in the SETUP mode.

### ■ Setting item: AUX NAME

#### Setting contents:

AUXILIARY (Initial setting) / TV / DVD / PORTABLE / GAME

## Playing MP3/WMA/AAC Data (PLAY MODE)

This unit can play back CDs containing both CD and MP3/WMA/AAC data (created in Enhanced CD (CD Extra) format). However, in some situations, playback of an enhanced CD may be difficult. In this case, you can choose to play back the CD data session only. When a disc contains both CD and MP3/WMA/AAC data, playback starts from the CD data portion of the disc.

### ■ Setting item: PLAY MODE

#### Setting contents:

CD-DA / CDDA/MP3 (Initial setting)

#### CD-DA:

Only the CD data in Session 1 can be played back.

#### CDDA/MP3:

CD data, MP3/WMA/AAC files in mixed mode, and multi-session discs can be played back.

#### Note

- Perform this setting before inserting a disc. If a disc has already been inserted, remove it.

## Setting the stay on mode

You can set the delay in turning OFF the unit's power after the vehicle's ignition is turned off (ACC OFF). When you select a mode other than OFF, the music will be paused after you turn the ignition key off (ACC OFF). At the same time, the prompt "PRESS PRESET 6 TO STAY ON" will scroll once. Press **6** within 15 seconds to continue enjoying music for the selected period. If **6** is not pressed, the unit will power off within 15 seconds. During this period, you can only receive a call by operating a paired Smartphone.

### ■ Setting item: STAY ON

#### Setting contents:

OFF (Initial setting) / 5 MIN / 15 MIN / 30 MIN

#### Notes

- Note that there is a possibility that the battery may be drained if already weak, during this period.
- The setting result of STAY ON will be cleared if you switch the 2WAY/3WAY system mode.

## Demonstration

This unit will enter a demonstration mode to display its various functions.

### ■ Setting item: DEMO MODE

#### Setting contents:

ON (Initial setting) / OFF / QUITE OFF

#### ON:

The unit starts the demonstration if there is no operation for 30 seconds.

#### OFF (Standby):

The demonstration mode is in the standby state. Note that if this unit is disconnected from the vehicle's battery, the next time you use this unit the demonstration mode will be ON.

#### QUITE OFF (Completely closed):

Close the demonstration mode completely.

## Display Setting

DISPLAY is selected on the setup main menu in step 2.

## Changing Lighting Color

You can change the lighting color of the unit's keys/display.

### ■ Setting item: ILLUMINATI

#### ■ Further setting items: KEY & DISP( Key & Display ) / KEY ( Key ) / DISP\* ( Display )

#### Setting contents:

OPTION / CUSTOMIZE

#### OPTION:

A total of 30 colors can be selected.

#### CUSTOMIZE:

If there is no color you prefer in OPTION, you can customize the color as follows.

- \* You can change the lighting colour of keys and display simultaneously or respectively by selecting KEY&DISP or KEY/DISP.

**1** After entering CUSTOMIZE, turn the Rotary encoder to select a color (RED, GREEN, BLUE) you want to adjust, and then press **Q** / ENTER.

**2** The adjusted color will blink, turn the Rotary encoder to select a value (0-60).  
R is red, G is green and B is blue.

**3** Press **Q** / ENTER or **↵** to finish the color setting.

**4** Repeat steps 1 to 3 to set another color.

#### Notes

- In step 2, you can switch to another color setting mode by pressing **◀◀** or **▶▶**.
- The setting values in OPTION mode and CUSTOMIZE mode are linked, when the setting value in CUSTOMIZE is different from the one in OPTION, "USER" will be displayed in OPTION mode.
- During CUSTOMIZE setting, at least one setting value should be greater than 20.

## Dimmer Control

Set the Dimmer control to AUTO to decrease the illumination brightness of the unit with the head lights of the vehicle ON. This mode is useful if you feel the unit's backlighting is too bright at night.

### ■ Setting item: DIMMER

#### Setting contents:

AUTO (Initial setting) / ON / OFF

#### Note

- You can also adjust this item by pressing and holding **DIM.**

## Scroll Setting (TEXTSCROLL)

This CD player can scroll the disc and track names recorded on CD-TEXT discs, as well as the text information of MP3/WMA/AAC files, folder names and tags.

### Setting item: TEXTSCROLL

#### Setting contents:

MANUAL (Initial setting) / AUTO

#### MANUAL:

The display is scrolled when a disc is loaded or when a track is changed, etc.

#### AUTO:

The current text information of CD, folder, tag, etc. is scrolled automatically.

#### Note

- The unit scrolls CD text names, folder names, file names or tag display.

## Scroll Type Setting

Choose from two scrolling methods. Select the type you prefer.

### Setting item: SCROLLTYPE

#### Setting contents:

TYPE1 / TYPE2 (Initial setting)

#### TYPE1:

The characters scroll from right to left, a single character at a time.

#### TYPE2:

Words are built up from left to right, a single character at a time. When the display is filled, it is cleared and the remaining words are displayed the same way until all words of the title have been shown.

## Tuner Setting

TUNER is selected on the setup main menu in step 2.

## Setting the TUNER (FM) tone quality (FM SET)

This unit can set your preferred tonal quality for the FM analog radio stations.

### Setting item: FM SET

#### Setting contents:

HI-FI / NORMAL (Initial setting) / STABLE

#### HI-FI:

High-quality setting

#### NORMAL:

Standard setting

#### STABLE:

Control noise

#### Note

- Noise may be more noticeable when HI-FI is set, depending on the reception status. In this case, the Normal setting is recommended.

## iPod Setting

“IPOD” is selected on the setup main menu in step 2.

## iPod/iPhone Search Mode Setting

The unit allows you to search the iPod/iPhone using nine different search modes.

### Setting item: IPOD LIST

**Further setting items:** PLAYLISTS / ARTISTS / ALBUMS / AUDIOBOOKS / PODCASTS / GENRES / COMPOSERS / SONGS / GENIUS MIX

#### Setting contents:

OFF / ON

#### Notes

- The search mode for Playlists/Artists/Albums/Podcasts/Genres/ Songs/ Genius Mix is initially set to On. The search mode for Audiobooks/ Composers is initially set to Off.
- For search mode details, refer to “Searching for a desired Song” on page 38.

## Application Setting (APP)

APP is selected on the setup main menu in step 2.

## Setting the communication mode with a Smartphone (ALPINE APP)

Set ALPINE APP to USB when an iPhone is connected, or set to BT when an Android or a BlackBerry Smartphone is paired.

### Setting item: ALPINE APP

#### Setting contents:

USB (Initial setting) / BT / OFF

#### USB:

When an iPhone is connected to CDE-W265EBT/CDE-164EBT's USB port, you can enjoy Pandora, program the unit's sound tuning parameters, or communicate with SNS.

#### BT:

Set this when an Android or a BlackBerry Smartphone is paired with this unit via Bluetooth technology. At this time, you can enjoy Pandora (program the unit's sound tuning parameters, or communicate with SNS. (Android only))

#### OFF:

No Smartphone is connected.

#### Notes

- It takes a few seconds to validate this function.
- For this function to work properly, specific applications must be installed on your Smartphone before connection. Consult your Alpine dealer or the Alpine website for details.
- Only the iPhone and certain Android/BlackBerry Smartphones support this function.

## Setting the TTS (Text To Speech) volume

This function allows for readout of comments, etc., on a Smartphone, and outputs sound from the speakers of the unit.

### Setting item: TTS VOLUME

#### Setting contents:

0 ~ 35

#### Note

- The initial volume level is 12.

# BT Hands Free Calling

## CDE-W265EBT

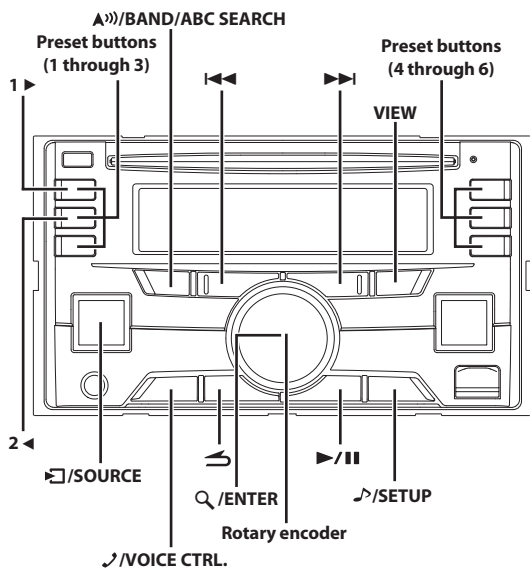

## CDE-164EBT

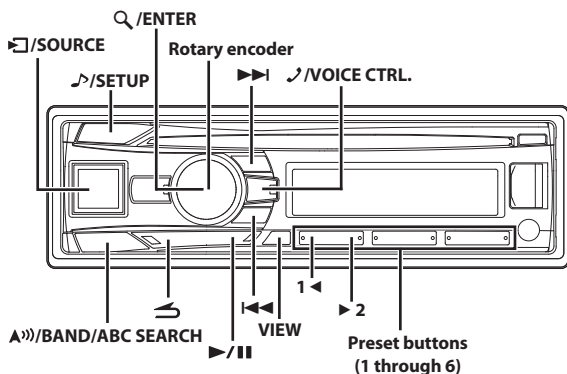

## Setup Before Using

### About Bluetooth®

Bluetooth is a wireless technology allowing communication between a mobile device or personal computer over short distances. This enables a hands-free call or data transmission between Bluetooth compatible devices. Bluetooth transmission is available in the unlicensed 2.4 GHz spectrum if the distance between devices is within 10 meters. For details, refer to the Bluetooth Home page (<http://www.bluetooth.com>).

#### Notes

- Depending on the Bluetooth version, a Bluetooth compatible device may not be able to communicate with this unit.
- Proper function of this unit with all Bluetooth compatible devices is not guaranteed. For handling of the BT compatible device, consult your ALPINE dealer or ALPINE website.
- Depending on the surroundings, Bluetooth wireless connection may be unstable.

- When you place a call, or perform setup operations, be sure to stop your car in a safe place.
- Depending on the connected Bluetooth compatible device(s), the function may differ. Also refer to the Owner's Manual of the connected device(s).
- When you search for this unit using the Bluetooth compatible phone, the unit name is displayed as "CDE-W265Series/CDE-164Series".

### Before Using Bluetooth Function

Before using the Bluetooth function, the following settings need to be made.

Set **BT IN** to **ON** when you want to use Hands-Free phone or BT Audio function. Refer to "Setting the Bluetooth Connection (BT IN)" on page 30.

#### Note

- Before using Bluetooth function, it must be paired with this unit. Refer to "How to connect to a Bluetooth compatible device (Pairing)" on page 29.

### How to connect to a Bluetooth compatible device (Pairing)

For details on the control from a Bluetooth compatible device, refer to the Owner's Manual of the Bluetooth compatible device.

- Using your Bluetooth compatible device, select the "CDE-W265Series/CDE-164Series" for pairing.

### For Bluetooth compatible device with SSP (Secure Simple Pairing)

- Turn the **Rotary encoder** to change the head unit display from "PAIR NO" to "PAIR YES", and then press **ENTER**. If "PAIR NO" is selected, the connection will be canceled.

### For Bluetooth compatible device without SSP (Secure Simple Pairing)

- Input the PIN code ("0000") in a Bluetooth compatible device.

#### Note

- The PIN code is fixed as "0000".

- If the pairing was successful, "CONNECTED" is displayed for a few seconds. The head unit then returns to its previous state.

### Auto pairing with an iPod/iPhone

When an iPod/iPhone is connected to the USB port, the unit will automatically pair with it.

- Make sure **USB PAIR** is set to **ON**. Refer to "Setting the Auto Pairing with iPod/iPhone" on page 30.
- Connect an iPod/iPhone to this unit's USB port.
- Turn the **Rotary encoder** to select "PAIR YES", and then press **ENTER**.\*

If "PAIR NO" is selected, the connection will be canceled.

- \* Depending on the iOS version, you may need to turn on the Bluetooth function manually on the iPod/iPhone side, then perform this step.

- 4** If pairing is successful, "CONNECTED" is displayed for a few seconds. The head unit then returns to its previous state.

#### Notes





- If the device has been paired with this unit previously, it will not USB Pair automatically.
- If the connection is unsuccessful, "FAILED" is displayed.
- After a successful pairing, the device and this unit should connect automatically whenever the vehicle's ignition is turned ON. If the auto reconnect fails, try to connect manually.
- Set "VISIBLE M" to ON, so this unit is visible to other Bluetooth compatible devices. Refer to "Setting the Visible Mode" on page 31.

## Bluetooth SETUP

The following steps 1 to 5 are common to the various Bluetooth functions. For details, refer to each individual function.

#### Note

- Set BT IN to ON, and then perform Bluetooth SETUP operation. Refer to "Setting the Bluetooth Connection (BT IN)" on page 30.

- 1** Press and hold  /SETUP for at least 2 seconds to activate the SETUP mode.
- 2** Turn the Rotary encoder to select "BLUETOOTH", and then press  /ENTER.  
The Bluetooth setup mode is activated.
- 3** Turn the Rotary encoder to select the desired items, and then press  /ENTER.  
BLUETOOTH:  
BT IN<sup>\*1</sup> ↔ USB PAIR ↔ PAIRED DEV ↔ VISIBLE M ↔ CALL SOUND ↔ CALLER ID ↔ PB UPDATE<sup>\*1</sup> ↔ PB ORDER ↔ SPEAKER SL<sup>\*2</sup> ↔ FW VERSION ↔ FW UPDATE<sup>\*1</sup> ↔ BT IN  
  
<sup>\*1</sup> The items are not displayed during a phone call.  
<sup>\*2</sup> Not displayed when 2WAY/3WAY system mode is set to 3WAY.
- 4** Turn the Rotary encoder to change the settings.
- 5** Press and hold  /SETUP for at least 2 seconds.  
The SETUP mode is canceled.

#### Notes

- Press  to return to the previous mode.
- If no operation is performed for 60 seconds, the unit will return to normal mode automatically.

## Setting the Bluetooth Connection (BT IN)

With Bluetooth technology, you can place a hands-free call by a Bluetooth-equipped Smartphone. Audio information of a Bluetooth compatible Smartphone, a portable audio player, etc., is controllable/playable wirelessly from this unit.

#### Setting item: BT IN

##### Setting contents:

OFF / ON (Initial setting)



##### OFF:

Hands-Free Phone function and Bluetooth Audio function are disabled.

##### ON:

Select when you want to pair your Bluetooth compatible phone with this unit or use Bluetooth Audio function.

#### Note

- When BT IN is set to OFF, the indicators related to Hands-free phone ( battery charge and  signal strength) will not be displayed.

## Setting the Auto Pairing with iPod/iPhone

By setting this item to ON, the unit will auto pair when an iPod/iPhone is connected to this unit via the USB port.

#### Setting item: USB PAIR

##### Setting contents:

OFF / ON (Initial setting)

##### OFF:

Turn off the auto pair function.

##### ON:

Auto pair when an iPod/iPhone is connected to this unit via the USB port.

##### Note

- USB Auto-Pairing cannot take place if either device has been paired previously. Make sure the device name of both has been deleted from each device.

## Setting the Bluetooth Device











Select one of 5 connected Bluetooth compatible devices that you previously registered.

#### Setting item: PAIRED DEV

- 1** Turn the Rotary encoder to select a Bluetooth compatible device you want to use (you want to change connection), and then press  /ENTER.
- 2** Turn the Rotary encoder to select "CONNECT" to connect the selected device.

The connected device is marked with . Select "DISCONNECT" to disconnect this device. Select "CLEAR" when you want to clear the device from the device list.

#### Notes

- If the connection is successfully changed, "CONNECTED" is displayed for 2 seconds and the  indicator lights up, then the display returns to the SETUP screen.
- If a Smartphone is connected to this unit successfully, the  indicator lights up to show the battery charge of the connected Smartphone. The  indicator lights up when the battery charge is about 50%, the  indicator lights up when the battery charge is not enough, and it blinks as a low level warning. The  indicator goes out when the battery is drained. At this time, the Bluetooth function is unavailable due to the Smartphone powered off.
- Indicator  (Signal Strength):  
The indicator will display the current signal strength of your service provider. The  indicator blinks when the signal of the connected Smartphone is very weak. The  indicator goes out when the Smartphone is not in service area or receives no signal.
- Depending on the connected Smartphone, the  (battery charge), and  (signal strength) indicators may not be displayed.
- A total of 5 devices can be registered. If a 6th device is registered, the earliest registered device will be deleted automatically.

## Setting the Visible Mode

You can set whether this unit can be recognized or not from a Bluetooth compatible device. Normally set this to ON.

### Setting item: VISIBLE M

#### Setting contents:

OFF / ON (Initial setting)

#### OFF:

Disable recognition of this unit from the Bluetooth compatible device.

#### ON:

Enable recognition of this unit from the Bluetooth compatible device.

## Setting the Bluetooth sound quality

Change these settings to improve the quality of the outgoing or incoming call.

### Setting item: CALL SOUND

### Further setting items: SOURCE VOL / TYPE SET

## Adjusting the volume (SOURCE VOL)

You can emphasize or weaken the volume level of the Phone call, the ring tone and the microphone input to fit your own preferences.

#### Setting contents:

##### PHONE TALK:

-5 dB ~ +5 dB

##### RING TONE:

-5 dB ~ +5 dB

##### MIC GAIN:

-5 dB ~ +5 dB

#### Note

- The initial setting of PHONE TALK / RING TONE / MIC GAIN is 0.

## Sound Auto setting (TYPE SET)

Depending on your calling environment, choose one of the settings below which gives the best sound quality.

#### Setting contents:

TYPE1 (Initial setting) / TYPE2 / TYPE3 / TYPE4 / TYPE5

#### TYPE1:

Standard Mode (recommended)

#### TYPE2:

Enhances the noise reduction

#### TYPE3:

Enhances the echo-cancel

#### TYPE4:

Enhances both noise reduction and echo-cancel

#### TYPE5:

Weakenes both noise reduction and echo-cancel

#### Note

- The functions below are designed to improve the sound quality of the outgoing call.  
Noise reduction: This function can reduce the road noise, but excessive enhancement may affect the sound quality of the call.  
Echo-cancel: This function can reduce the echo, but excessive enhancement may affect the sound quality of the call.

## Setting the caller information display ON/OFF

You can choose whether to use this function according to the following setting.

### Setting item: CALLER ID

#### Setting contents:

OFF / ON (Initial setting)

If you want to keep the ID information of the caller from others, set this item to OFF. Depending on the stored ID information, "UNKNOWN" and telephone number will be displayed.

## Setting the Phone Book Update

You can update the phone book automatically or manually.

### Setting item: PB UPDATE

### Further Setting contents: AUTO/MANUAL

## Setting the Phone Book Auto Update ON/OFF (AUTO)

When you select AUTO ON in this step, whenever the vehicle's ignition is turned ON or after the phone is connected with this unit, the phone book will be updated automatically.

#### Setting contents:

AUTO OFF / AUTO ON (Initial setting)

#### Note

- "UPDATING" will be displayed during the phone book update.

## Setting the Phone Book Manual Update ON/OFF (MANUAL)

When you select MANUAL YES in this step, the phone book will be updated immediately regardless if the Auto update function is on or off.

#### Setting contents:

MANUAL NO (Initial setting) / MANUAL YES

#### Note

- "UPDATING" will be displayed during the phone book update.

## Changing the Phone book List Order

The phone book is listed alphabetically by the first letter of FIRST or LAST NAME.

Listing by FIRST NAME is the default but LAST NAME can be selected.

### Setting item: PB ORDER

#### Setting contents:

FIRST NAME (Initial setting) / LAST NAME

#### Note

- "WAITING" will be displayed while the Phone book order is switching. You can quit the "WAITING" screen to perform other operations by pressing  when the ordering is still in progress. At this time, the phone book is not accessible. In addition, the ordering may affect the playback of BT AUDIO.

## Selecting the output speaker

Choose the speaker in your vehicle from which you want to hear the call.

### Setting item: SPEAKER SL

#### Setting contents:

ALL (Initial setting) / FRONT-L / FRONT-R / FRONT-LR

#### ALL:

The sound be output from all of speakers in car.

#### FRONT-L:

The sound only be output from the front left speaker.

#### FRONT-R:

The sound only be output from the front right speaker.

#### FRONT-LR:

The sound be output from the front left and front right speaker.

#### Note

- In 3WAY mode, the call sound is output from all of speaker in car.

## Displaying the firmware version

The current firmware version will be displayed.

### Setting item: FW VERSION

## Updating the firmware

Future Bluetooth firmware updates may become available for phone interoperability.

For information to update your Bluetooth firmware, please visit your local Alpine website or choose your country from Alpine home page (<http://www.alpine-asia.com>).

### Setting item: FW UPDATE

#### Setting contents:

NO (Initial setting) / YES

## Hands-Free Phone Control

### About the Hands-Free Phone

Hands-free calls are possible when using a HSP (Head Set Profile) and HFP (Hands-Free Profile) compatible Smartphone with this unit.

#### Notes

- Avoid performing a hands-free call in heavy traffic or on narrow or winding streets.
- Close the windows while calling to reduce background noise.
- If both calling parties are using hands-free devices, or the call is made in a noisy location, difficulty hearing the other person's voice is normal.
- Depending on telephone line conditions or certain mobile devices used, voices may sound unnatural.
- When using a microphone, speak as directly as you can into the microphone to pick up the best sound quality.
- Certain Smartphone features are dependent on the capabilities and settings of your service provider's network. Additionally, certain features may not be activated by your service provider, and/or the provider's network settings may limit the feature's functionality. Always contact your service provider about feature availability and functionality.

All features, functionality, and other product specifications, as well as the information contained in the Owner's Manual are based upon the latest available information and are believed to be accurate at the time of printing.

Alpine reserves the right to change or modify any information or specifications without notice or obligation.

## Answering a Call

Incoming calls are announced by the received call ring tone and a displayed message (PHONE).

Press  or  /ENTER.

The call starts.

#### Note

- While calling, the source sound on the unit is muted. After calling, playback will resume.

## Hanging up the Telephone

Press  or .

The call finishes.

## Calling

Call History is recorded for the last dialed/received/missed calls (20 records for each). There are various ways of making calls based on the "Calling". The following steps 1 to 5 are common to the various ways of making these calls. For details, refer to each individual category for making calls.

### 1 Press .

The outgoing method list is displayed.

### 2 Turn the Rotary encoder to select the outgoing mode.

#### Setting contents:

DIALED / RECEIVED / MISSED / PHONE BOOK

#### DIALED:

Dialed history

#### RECEIVED:

Received history

#### MISSED:

Missed incoming history

#### PHONE BOOK:

Smartphone phone book

### 3 Press /ENTER.

The outgoing mode is activated, and each mode list is displayed.

#### Note

- It may take some time for the list to be displayed after connection. This list may not always update, depending on the connected device.



### 4 Turn the Rotary encoder to select a name or a telephone number from the list.

#### Note

- You can use Phone book alphabet search function to search a name or number from Phone Book. For details, refer to "Phone book Alphabet Search Function" on page 33.

### 5 Press /ENTER.

The selected telephone number will be called.

If one name has several numbers registered in the telephone book, press  /ENTER after selecting the name<sup>®</sup>, and then turn the Rotary encoder to choose the desired number and press  /ENTER, the telephone will be called.

- \* If the name cannot be recognized, the telephone number will be displayed.

#### Notes

- Press  to return to the previous mode.
- If no operation is performed for 60 seconds, the unit will return to normal mode automatically.

## Redialing a Number In Outgoing History

Previously dialed telephone numbers (maximum number of call records is 20) are stored in dialed calls history. You can redial a number by searching from dialed calls history.

■ **Setting item:** DIALED

## Dialing a Number In Incoming History

Telephone numbers from received calls (maximum number of call records is 20) are stored in the Received List. You can redial these numbers by searching here.

■ **Setting item:** RECEIVED

## Dialing a Number In Incoming Missed Call History

Telephone numbers for received calls (maximum number of call records is 20) that are missed, are stored in the Missed List. You can redial these numbers by searching here.

■ **Setting item:** MISSED

## Dialing a Number In The Phone Book

Up to 1,000 names (at most 5 telephone numbers for each name) are downloadable from a Smartphone. Dial a call by selecting a person from the phone book list.

■ **Setting item:** PHONE BOOK

### Notes

- The order of the list display depends on the setting of "PB ORDER" (refer to "Changing the Phone book List Order" on page 31).
- If the call history or phone book of the Smartphone is added or deleted while it is connected to the unit, the list displayed on the unit may not be brought up to date. If it is not updated, you cannot correctly place a call.
- You can display the information of a number stored in phone book by pressing **VIEW**. Each press changes the display as Name → Telephone label / Telephone NO. → Name  
If the name cannot be obtained, the number will be displayed. If the label or number cannot be obtained, "NO LABEL" or "NO NUMBER" will be displayed.
- \* The telephone label of a number depends on the number information stored in Phone book of the Smartphone, which includes 4 types-MOBILE, HOME, OFFICE and OTHER.

## Phone book Alphabet Search Function

You can select the first three letters to search for a desired name in phone book list by using the Phone book alphabet search function.

### For example:

Searching a name "Michael James"

The following example explains how the search is performed.

Depending on the setting in PB ORDER (refer to "Changing the Phone book List Order" on page 31), the phone book is listed in first name or last name order. Please search for the first name or last name according to the setting.

**1** Press **BAND/ABC SEARCH** while in the phone book list, the phone book alphabet search mode is activated.

The letter selection screen is displayed.

**2** Turn the **Rotary encoder** to select the first letter (e.g. M), and then press **▶▶I**.

**3** Turn the **Rotary encoder** to select the second letter (e.g. l), and then press **▶▶I**.

**4** Turn the **Rotary encoder** to select the third letter (e.g. C), and then press **Q / ENTER**.

The names stored in phone book which begin with "MIC" are searched.

**5** Turn the **Rotary encoder** to select the desired name (e.g. Michael James), and then press **Q / ENTER** to make the call.

### Notes

- The Alphabet Search Function is only applicable to English alphabet characters.
- If the selected name has more than one number registered in the phone book, you need to turn the **Rotary encoder** to select the desired number, and then press **Q / ENTER**.
- Press **I◀◀** in step 3 or 4 to delete the current entry and return to the previous step.
- You can search for a name by its first letter, first two letters or first three letters. Press **Q / ENTER** after entering the desired number of letters. A list displays the names beginning with the entered letter(s).

## Voice Control Operation

When a Smartphone equipped with voice recognition function is paired with this unit, the Smartphone can be controlled by Voice Control via this unit.

**Press and hold VOICE CTRL. for at least 2 seconds to activate the Voice Recognition mode.**

After the Voice Recognition mode is activated and "SPEAK" is displayed, you can make a phone call, play a song, etc., via this unit by inputting voice control commands\*.

\* Please refer to your Smartphone manual for other voice control commands.

### Notes

- You can perform this operation only when a Voice recognition compatible Smartphone is connected. If the Smartphone is not compatible with the Voice recognition, "NO SUPPORT" is displayed for 2 seconds.
- The Voice recognition performance depends on the Smartphone and mounting location of the microphone. Please pay attention when the microphone is mounted.
- Voice recognition operation depends on the function of the Smartphone. For details, refer to the Owner's Manual of the Smartphone.
- If the person you are calling is not found, "NO CALL" is displayed for 2 seconds.
- Please obey all local traffic laws while using this function.

## Call waiting function

If a second call is received during a current call, you can have the first caller wait momentarily while you take the second call. When you are finished with one call, you can switch to the other one.

**If a second call is received during the current call (call1), the information of second caller (call2) is displayed instead of the current caller's name. Press 2, the call waiting mode is activated.**

In this case, call1 is on hold, while you take call2.

### Notes

- In the call waiting mode, press **1** or **2** to switch between the current call and the person on hold.
- In the call waiting mode, press and hold **1** or **2** for at least 2 seconds to hang up call1 or call2, and the other call will be answered automatically. (The action depends on the paired device.)

- In the call waiting mode, you can press **VIEW** to change the display between the current call and the person on hold.

## Preset a number in the Phone Menu (Shortcut dial)

Assign numbers that you dial frequently to presets for quick recall. You can assign up to six frequently called phone numbers to number presets.

Select a number you want to preset from the Phone Menu list (PHONE BOOK, DIALED, etc.). Press and hold any one of the preset buttons (1 through 6) as the one that you wish to store the number for at least 2 seconds.

The phone number you selected is stored in presets.

### Notes

- If the name has several numbers registered in the phone book, press **Q/ENTER** after selecting the name. Turn the **Rotary encoder** to choose the desired number. Press and hold any one of the **preset buttons (1 through 6)** for at least 2 seconds. The selected number is stored as a preset number.
- A total of 30 phone numbers can be stored in the preset memory ( 6 numbers for each Smartphone in the paired device list). If a Smartphone is deleted from the paired device list, the stored preset numbers of this Smartphone are deleted, even when it is paired again.
- If you store a phone number in a preset with a previously stored number, the current number will be cleared and replaced by the new one.

## Dialing the preset number

- 1 Press any one of the **preset buttons (1 through 6)** that has had a number stored in the phone mode.

The information (name/number) stored in the preset station is displayed.

- 2 Press **Q/ENTER** or **↶**.

The stored preset number is dialed directly.

## Adjusting the volume when receiving a Call

While calling, you can adjust the volume.

Turn the **Rotary encoder** to adjust the volume.

### Note

- You may need to increase volume from your regular audio listening source level. However, increasing the volume excessively may result in feedback. Feedback is directly related to the volume. Turning down the volume as low as acceptable, will reduce it. Positioning the microphone in a direction away from the main car speakers (e.g. clipped on sun visor) may also reduce feedback at high volume.

## Muting the microphone input quickly (Voice Mute)

During a call, activating the Voice Mute function will instantly mute the microphone input. Your voice will not be heard by the caller.

During a call, press **▶/II** to mute the microphone input.

Press **▶/II** again to bring the microphone input back to its previous volume level.

## Call Switching Operation

During a call, this function allows you to initiate the transfer of the audio between the Smartphone and the speakers in the car.

During a call, press **▲)) / BAND** or press and hold **▶/II** for at least 2 seconds to switch the call sound between the unit and Smartphone.

### Note

- Depending on the Smartphone, this operation may not be possible.

## Bluetooth Audio Operation

With a Bluetooth compatible Smartphone or music player, it's possible to play and control music playback wirelessly\*.

- \* To play back audio, a Smartphone or a portable player conforming to A2DP (Advanced Audio Distribution Profile) and AVRCP (Audio/Video Remote Control Profile) is required. Not all functions work with all devices.

### Notes

- Set **BT IN** to **ON** when you want to use Bluetooth Audio function. Refer to "Setting the Bluetooth Connection (BT IN)" on page 30.
- During a call, sound on the Bluetooth audio source is muted.
- If you operate the Hands-free phone (e.g. searching in the phone book) while using the Bluetooth Audio function, Bluetooth Audio playback may be affected.

## Recalling the Bluetooth Audio Mode

Press **☐/SOURCE** to select the BT AUDIO mode.

## Selecting the desired Song

Press **I◀◀** or **▶▶I** to select the desired Song.

Pressing and holding **I◀◀** or **▶▶I** will fast backward/fast forward track continuously.

### Note

- The action depends on the paired device.

## Pausing

Press **▶/II**.

A playback stops. Pressing again will resume a playback.

## Selecting the desired Group

Press **◀** or **▶** to select the desired Group.

### Note

- This function is not available on all paired devices.



## Searching for a desired song

Artist name, album name, etc., may be searched and displayed during playback or pause.

- 1 Press **Q** /ENTER to activate the search mode.
- 2 Turn the **Rotary encoder** to select the desired Group (Folder), and then press **Q** /ENTER.
- 3 Turn the **Rotary encoder** to select the desired album, folder, etc., within the selected Group (Folder), and then press **Q** /ENTER.
- 4 Repeat step 3 if necessary until the desired song is found.

### Notes

- Search mode may differ depending on the paired device.
- The pause mode may be canceled after the search.
- This function may not be available depending on the paired device.

## USB Memory (optional)

### CDE-W265EBT

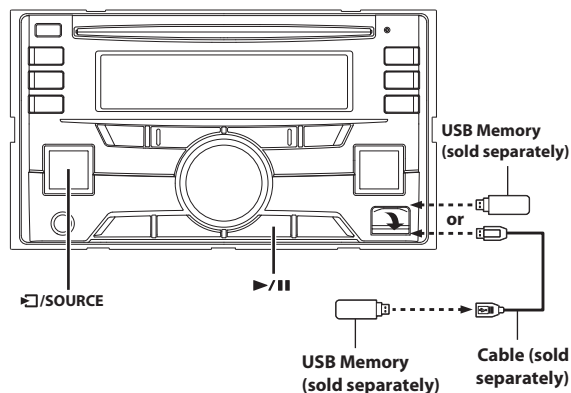

### CDE-164EBT

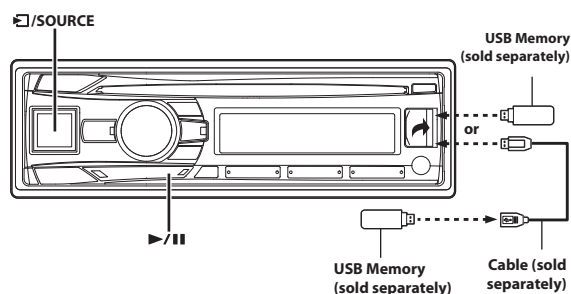

## Playback MP3/WMA/AAC Files from USB Memory (optional)

If a USB Memory device is connected to the unit, MP3/WMA/AAC files can be searched and played back.

- 1 Press **Q** /SOURCE to select the USB AUDIO mode.
- 2 To pause playback, press **▶/II**.  
Pressing **▶/II** again will resume playback.

### Notes

- This unit plays back files in USB Memory with the same controls and modes used for playback of CDs containing MP3/WMA/AAC. For details, refer to "CD/MP3/WMA/AAC" on page 12.
- The root folder is displayed as "ROOT".
- Before disconnecting USB Memory, be sure to change to another source or set to pause.
- The playback time may not be correctly displayed when a VBR (Variable Bit Rate) recorded file is played back.

## About MP3/WMA/AAC File of USB Memory

### Playing back MP3/WMA/AAC

MP3/WMA/AAC files are prepared, then stored to a USB Memory Device. This unit can recognize at most 255 folders and 255 files per folder stored in USB Memory. Playback may not be performed if a USB Memory Device exceeds the limitations described above. Do not make a file's playback time more than 1 hour.

### Media supported

This device can play back files stored on USB Memory devices designed for USB connection.

### Corresponding File Systems

This device supports FAT 12/16/32 for USB Memory devices.

## iPod/iPhone (optional)

### CDE-W265EBT

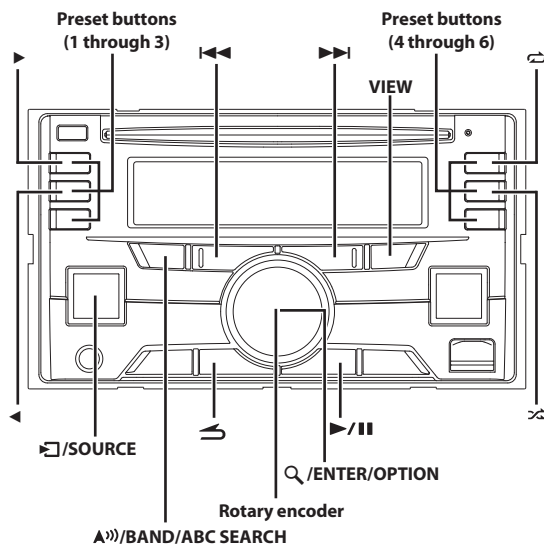

### CDE-164EBT

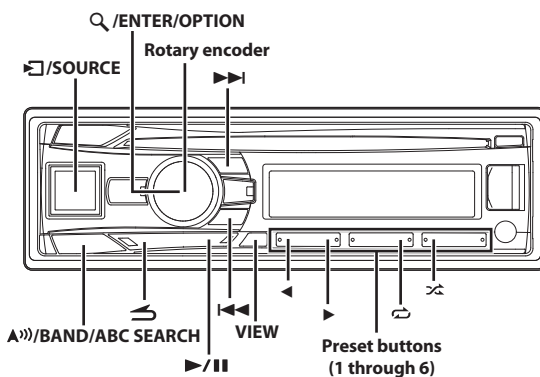

## Connecting an iPod/iPhone

An iPod/iPhone can be connected to this unit by using the Interface cable for iPod (included with iPod/iPhone). When an iPod/iPhone is connected to this unit, you can choose to control the iPod/iPhone using its own controls or by the head unit controls. For details, refer to “Setting the iPod Control” on page 37.

### ■ CDE-W265EBT

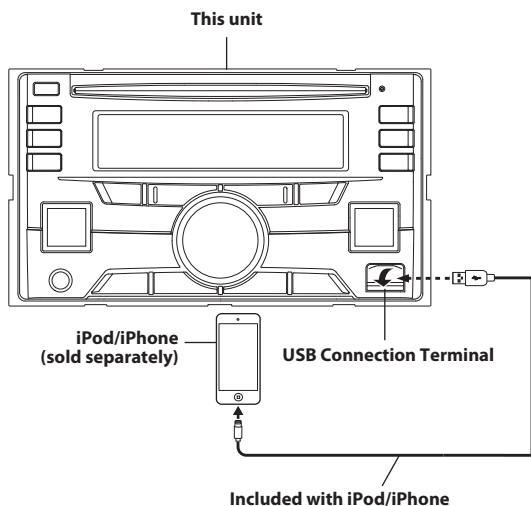

### ■ CDE-164EBT

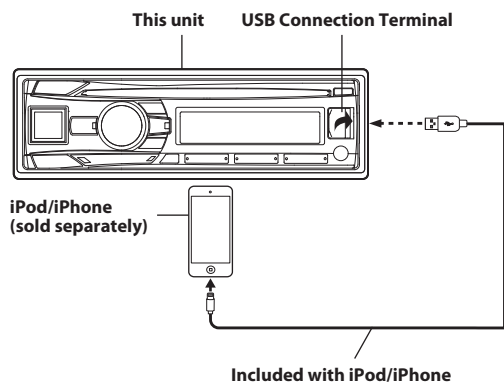

#### Notes

- Internet and telephone functions of the iPod touch or iPhone, etc., can also be used when connecting to this unit. However, using these functions will stop or pause the currently playing songs. At this time do not operate the unit to avoid a malfunction.
- An iPhone connected to this unit is usable as an iPod or a hands-free phone. The iPhone must be paired with the unit's Bluetooth to use the hands-free function.
- Do not leave an iPod/iPhone in a car, as its mechanism is sensitive to high temperature and humidity conditions, and damage may result.

#### About iPod/iPhone models usable with this unit

- The following devices have been certified following Made for iPod guidelines. Correct function of earlier versions cannot be guaranteed.
  - iPod nano (7th generation): Ver.1.0.2
  - iPod touch (5th generation): Ver.7.0.4
  - iPod touch (4th generation): Ver.6.1.3
  - iPod nano (6th generation): Ver.1.2
  - iPod touch (3rd generation): Ver.5.1.1

- iPod nano (5th generation): Ver.1.0.2
- iPod classic (160 GB) (Late 2009): Ver.2.0.4
- iPod touch (2nd generation): Ver.4.2.1
- iPod nano (4th generation): Ver.1.0.4
- iPod classic (120 GB): Ver.2.0.1
- iPod touch (1st generation): Ver.3.1.3
- iPod nano (3rd generation): Ver.1.1.3
- iPod classic (80 GB, 160 GB): Ver.1.1.2

- The following devices have been certified following Made for iPhone guidelines. Correct function of earlier versions cannot be guaranteed.
  - iPhone 5s: Ver.7.1.1
  - iPhone 5c: Ver.7.1.1
  - iPhone 5: Ver.7.1.1
  - iPhone 4s: Ver.7.1.1
  - iPhone 4: Ver.7.1.1
  - iPhone 3GS: Ver.6.1.6
  - iPhone 3G: Ver.4.2.1
  - iPhone: Ver.3.1.3
- For clarity in identifying your model of iPod, please see Apple's own document "Identifying iPod models" at <http://support.apple.com/kb/HT1353>
- This unit does not support video playback from iPod/iPhone, even using a video-compatible cable.

## Setting the iPod Control

When an iPod/iPhone is connected, operate it from its own controls or from the head unit.

- Press and hold **Q/ENTER/OPTION** for at least 2 seconds during iPod source.

The Option menu for iPod mode is activated.

- Turn the **Rotary encoder** to select APP DIRECT, and then press **Q/ENTER**.

The iPod control mode will be switched between iPod MODE and HU MODE.

#### HU (HEAD UNIT) MODE:

Operate the iPod/iPhone via this unit.

This mode allows you to use M.I.X. play, repeat and music search in an iPod/iPhone from the head unit.

#### Note

- In HU MODE, if you operate from an iPod/iPhone, the head unit's display and operations may not correspond with those of the iPod/iPhone.

#### iPod MODE:

Operate the iPod/iPhone using its own controls. When iPod MODE is selected, some functions will not be operable via the head unit.

#### Notes

- During HU MODE, you can switch to iPod MODE directly by pressing **▲/BAND**.
- Once the control mode is changed, the iPod/iPhone is paused. Press **▶/II** to continue.

## Playback

- Press **◀/SOURCE** to switch to the iPod source.
- Press **◀◀** or **▶▶** to select the desired song. Pressing and holding **◀◀** or **▶▶** will fast backward/fast forward the current track.
- To pause playback, press **▶/II**. Pressing **▶/II** again will resume playback.

## Notes

- A song playing on the iPod/iPhone while it is connected to this unit will continue to play from where it was paused after disconnection.
- If you listen to an episode from a selected Podcast or Audiobook, the episode can be changed by pressing ◀ or ▶.
- An episode may have several chapters. The chapter can be changed by pressing ◀◀ or ▶▶.

## Searching for a desired Song

An iPod/iPhone can contain hundreds of songs. Use one of the search modes listed below, that you deem most effective in finding a desired song.

Each music category has its own individual hierarchy. Use the Playlist/Artist/Album/Song/Podcast/Genre/Composer/Audiobook/Genius Mix List search mode to narrow searches based on the table below.

Hierarchy 1	Hierarchy 2	Hierarchy 3	Hierarchy 4
Playlist	Song	—	—
Artist*	Album*	Song	—
Album*	Song	—	—
Song	—	—	—
Podcast	Episode	—	—
Genre*	Artist*	Album*	Song
Composer*	Album*	Song	—
Audiobook	—	—	—
Genius Mix List	—	—	—

### For example:

Searching by Artist name

The following example explains how an ARTIST search is performed.

Selecting another search category operates in the same manner but using a different hierarchy.

**1** Press **Q /ENTER** to activate the search selection mode.

**2** Turn the **Rotary encoder** to select the **ARTIST** search mode, and then press **Q /ENTER**.

SHUFFLEALL\*1 ↔ PLAYLIST ↔ ARTIST ↔ ALBUM ↔ SONG ↔  
PODCAST ↔ GENRE ↔ COMPOSER ↔ AUDIOBOOK ↔  
GENIUS MIX\*2/3 ↔ SHUFFLEALL

\*1 Refer to “Random Play Shuffle (M.I.X.)” on page 39.

\*2 Depending on the connected iPod/iPhone, Genius Mix function may not be supported.

\*3 When an iPod/iPhone with Genius Mix List created by iTunes is connected to this unit, GENIUS MIX search mode can be used to search a Genius Mix List.

### Note

- The display of search mode list varies depending on the setting of iPod LIST. For details, refer to “iPod/iPhone Search Mode Setting” on page 28.

**3** Turn the **Rotary encoder** to select the desired **Artist**, and then press **Q /ENTER**.

**4** Turn the **Rotary encoder** to select the desired **Album**, and then press **Q /ENTER**.

**5** Turn the **Rotary encoder** to select the desired **Song**, and then press **Q /ENTER**.

## Notes

- This function is unavailable when iPod MODE is selected in “Setting the iPod Control” (refer to “Setting the iPod Control” on page 37). And “iPod CONTROL” will be displayed.

- After pressing and holding **Q /ENTER** for at least 2 seconds while in each hierarchy (except SONG, AUDIOBOOK and GENIUS MIX List hierarchy), all songs of the selected hierarchy are played back.
- Playback [ALL] is only applicable for those categories marked with\*, press and hold **Q /ENTER** for at least 2 seconds to play back all songs in the iPod/iPhone or selected search mode.
- If no operation is performed for 60 seconds, the search mode is canceled. In the search mode, pressing **↵** will return to the previous mode.
- When search is made during M.I.X. play, the M.I.X. play mode will be canceled.
- When search is made during song downloading on iPhone, “UPDATING” will be displayed for a few second and the search mode will be canceled.
- “NO SONG” will be displayed if there are no songs in the selected playlist in the PLAYLIST search mode.
- “NO PODCAST” will be displayed if there is no podcast data in the iPod/iPhone in the PODCAST search mode.
- “NO AUDIOBOOK” will be displayed if there is no audiobook data in the iPod/iPhone in AUDIOBOOK search mode.
- “NO GENIUS” will be displayed if there is no genius mix list data in the GENIUS MIX search mode.
- If “iPod name” stored in the iPod/iPhone is selected in the Playlist search mode, and **Q /ENTER** is pressed, you can search for all songs in the iPod/iPhone. Also, if you press and hold **Q /ENTER** for at least 2 seconds, all songs in the iPod/iPhone are played back.
- Depending on the iPod/iPhone, podcast search is not supported.
- Press any of the **preset buttons (1 through 6)** during a search to skip over a calculated percentage of songs. For details, refer to “Direct Search Function” on page 38.
- During search mode, a search can be made quickly by Alphabet search function to find the desired artist or song, etc. For details, refer to “Alphabet Search Function” on page 39.

## Direct Search Function

The unit’s direct search function can be used to search for an album, song, etc., more efficiently. In PLAYLIST/ARTIST/ALBUM/SONG/PODCAST/GENRE/COMPOSER/AUDIOBOOK mode, you can quickly target any song.

**In the search mode, press any one of the preset buttons (1 through 6) to quickly skip over a designated percent of your song content.**

### Song search example:

If there are 100 songs in your iPod/iPhone, they are divided into 6 groups using percentages (shown below). These groups are assigned to the preset buttons (1 through 6).

#### Example 1:

Suppose the song you are searching for is located at around the middle (50%) of your library: press button 4 to jump to the 50th song and turn the **Rotary encoder** to find the desired song.

#### Example 2:

Suppose the song you are searching for is located near the end (83%) of your library: press button 6 to jump to the 83rd song and turn the **Rotary encoder** to find the desired song.

	All 100 songs (100%)					
	0%	17%	33%	50%	67%	83%
Preset buttons	1	2	3	4	5	6
Songs	1st song	17th song	33rd song	50th song	67th song	83rd song

## Notes

- This function is inactive during Alphabet Search mode.
- This function is also applicable to CD/MP3/WMA/AAC search.

---

## Select Playlist/Artist/Album/Genre/ Composer/Episode

---

Playlist/Artist/Album/Genre/Composer/Episode can be easily changed. For example, if you listen to a song from a selected album, the album can be changed.

Press ◀ or ▶ to select the desired Playlist/Artist/Album/  
Genre/Composer/Episode.

### Notes

- If the song search mode was used to select a song, this function is inactive.
- If an album is selected during an artist search, other albums by that artist are searchable.
- This function is inactive during shuffle (M.I.X.) playback.

---

## Alphabet Search Function

---

Quickly find an artist, album, etc. by the first letter in its title or name.

**1** During search mode, press BAND/ABC SEARCH to activate Alphabet Search function.

**2** Turn the Rotary encoder to select the desired initial letter (e.g. select "M"), and then press Q /ENTER.

A list which begins with the selected initial letter is searched.

**3** Turn the Rotary encoder to select the desired item (which begins with initial letter "M"), and then press Q /ENTER.

The item is selected.

### Notes

- The Alphabet Search Function is only applicable to English alphabetic characters.
- While in Alphabet search mode, pressing ⏪ will return to the previous mode.
- If the PLAYLIST search mode is used to search for a song, the Alphabet search function is inactive in the song search hierarchy.
- This function is unavailable when GENIUS MIX is selected.

---

## Search Position Memory

---

During iPod/iPhone playback, you can quickly return to the last-selected hierarchy level in the search mode.

Press ⏪.

The hierarchy you selected last in the search mode is displayed.

### Note

- This function is unavailable when iPod MODE is selected in "Setting the iPod Control" (refer to "Setting the iPod Control" on page 37).

---

## Random Play Shuffle (M.I.X.)

---

The Shuffle function of the iPod/iPhone is displayed as  on this unit.

### Shuffle Albums:

The songs on each album are played back in the order they were recorded. Upon completion of all the songs on the album, the next album is selected randomly. This continues until all albums have been played.

### Shuffle Songs:

Song shuffle randomly plays back songs within a selected category (playlist, album, etc.). The songs within the category are played just once until all songs have been played.

**1** Press .

The songs are played back in random sequence.

MIX ALBUM\*<sup>1</sup> → MIX SONG\*<sup>2</sup> → MIX OFF → MIX ALBUM

\*<sup>1</sup> Shuffle Albums.

\*<sup>2</sup> Shuffle Songs.

**2** To cancel M.I.X. play, select (MIX OFF) with the above procedure.

### Note

- If a song is selected in the album search mode before selecting M.I.X. play, the songs will not play back randomly even when Shuffle Albums is selected.

### Shuffle ALL:

Shuffle ALL plays all songs in the iPod/iPhone randomly. Any one song does not play back again until all songs have been played back.

**1** Press Q /ENTER to activate the search selection mode.

**2** Turn the Rotary encoder to select SHUFFLEALL, and then press Q /ENTER.

To cancel M.I.X. play, press  to select OFF.

### Notes

- If Shuffle ALL is selected, the selected songs being played back in the search mode are canceled.
- This function is unavailable when iPod MODE is selected in "Setting the iPod Control" (refer to "Setting the iPod Control" on page 37).

---

## Repeat Play

---

Only Repeat One is available for the iPod/iPhone.

### Repeat One:

A single song is repeatedly played back.

**1** Press .

The song is played back repeatedly.

REPEAT ONE\* → REPEAT OFF → REPEAT ONE

\* Repeat One.

**2** To cancel repeat play, select (REPEAT OFF) with the above procedure.

### Note

- Depending on the connected iPod, track up/down may be not available during Repeat play.

## Displaying the Text

You can display the tag information of a song in the iPod/iPhone.

Press **VIEW**.

Each press changes the display.

### Note

- When the **TEXTSCROLL** is set to **MANUAL**, press and hold **VIEW** for at least 2 seconds, the current text will be scrolled one time.  
TRACK NO./ELAPSED TIME → ARTIST NAME\*/SONG TITLE\* →  
ALBUM NAME\*/SONG TITLE\* → TRACK NO./CLOCK →  
TRACK NO./ELAPSED TIME

### \* TAG information

"ARTIST"/"ALBUM"/"SONG" is displayed if there is no tag information.

### Notes

- The maximum number of characters for the head unit is 70 (70 byte).
- Some characters may not be correctly displayed.

## Pandora® internet radio (Optional)

### ■ CDE-W265EBT

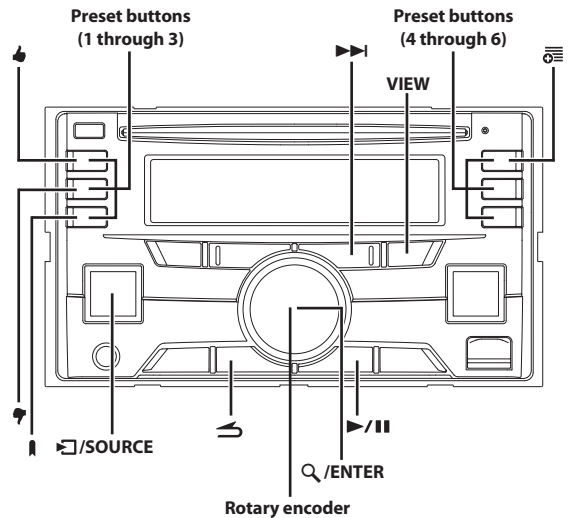

### ■ CDE-164EBT

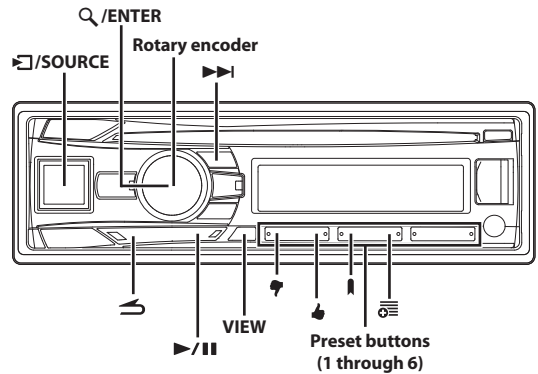

Pandora® internet radio is your own FREE personalized radio now available to stream music on your Smartphone (which runs Android OS, BlackBerry OS or iOS).

Just start with the name of one of your favorite artists, songs or classical composers and Pandora® will create a "station" that plays their music and more music like it.

The unit enables you to interact with your Pandora® account by connecting a Smartphone that has the latest version of the Pandora® application installed.





### Notes

- Some Pandora® application functions are not available when using this unit.
- Pandora® is also controllable from an iPod touch with Wi-Fi connection.
- Pandora® is available on iOS, Android OS and BlackBerry OS with this unit.
- Before this operation, set **ALPINE APP** to **USB** or **BT** depending on the connected Smartphone. For details, refer to "Application Setting (APP)" on page 28.

---

## Listening to Pandora®

---

- 1 Connect a Smartphone with the latest version of Pandora® installed.
- 2 Press  /SOURCE to switch to the PANDORA mode.
- 3 To pause playback, press /||. Pressing /|| again will resume playback.
- 4 To skip to the next song, press .

### Notes



- The operation to replay a previous song is not available.
- Pandora® limits the number of skips allowed on their service. If you attempt to skip songs beyond the limit, "SKIP LIMIT REACHED" is displayed.
- The unit remembers the source just before turning off the power. If Pandora® is the last SOURCE to be played, it will appear as the SOURCE the next time the unit is power up even if the app is not launched on your iPhone.
- Pandora® audio could drop out in areas with poor phone coverage.
- The display content varies when ads are received.
- The playback time may not be correctly displayed.





---

## "Thumbs" Feedback

---

You can personalize your stations with "THUMBS UP" or "THUMBS DOWN" feedback, which the system takes into account for future music selections.

During playback, press  or  for thumbs up or thumbs down.

- : The "" icon appears in the display. Pandora® will add similar music to your station.
- : The "" icon is displayed. Pandora® will ban that song from your station, and the current song is skipped. If the number of skips allowed has reached its limit, the current song continues to play back.

### Note

- In some situations, "THUMBS" feedback may not be available. "PLEASE TRY AGAIN" will be displayed.

---



## Searching for a Desired Station

---



You can display your station list and select stations directly from this unit.

- 1 Press  /ENTER to activate the Search mode.



### Alphabet Search:

- 2 Turn the Rotary encoder to select "A-Z", and then press  /ENTER. The "A-Z" search mode is activated and the station names are listed alphabetically.
- 3 Turn the Rotary encoder to select the desired station, and then press  /ENTER. Pandora® will play that station.



### Search by Date Added:

- 2 Turn the Rotary encoder to select "BY DATE", and then press  /ENTER. The "BY DATE" search mode is activated and the station names are listed by the date they were added to the account.
- 3 Turn the Rotary encoder to select the desired station, and then press  /ENTER. Pandora® will play that station.

### Genre Search:

- 2 Turn the Rotary encoder to select "GENRE", and then press  /ENTER. The "GENRE" search mode is activated and all the genre types are listed.
- 3 Turn the Rotary encoder to select the desired genre type, and then press  /ENTER. The stations of the desired genre are listed.
- 4 Turn the Rotary encoder to select the desired station, and then press  /ENTER. Pandora® will play that station.

### Notes



- The shared station is marked with "" in search list. The current station is marked with "" in the search list. And then if the current station is a shared station, the station will be marked with "".
- If any one of the preset buttons (1 through 6) is pressed in the search mode, a search can be made quickly by skipping the specified number of channels. For details, refer to "Direct Search Function" on page 38.
- When the desired station can't be found, turn to SHUFFLE mode to select station randomly.

---

## Shuffle

---

Use Shuffle to create a playlist based on two or more of your Pandora® stations. Edit your Shuffle station selections on the Pandora® Compatible Application for iPhone when it is not connected to this unit.

- 1 Press  /ENTER to activate the Search mode.
- 2 Turn the Rotary encoder to select "A-Z" or "BY DATE", and then press  /ENTER. The "A-Z" or "BY DATE" search mode is activated and the station name is displayed.
- 3 Press  /ENTER while selecting "SHUFFLE".

### Notes

- The songs from the created stations are played back in random sequence.
- Select another station during search mode to cancel Shuffle.
- During search list mode, the  icon will be displayed when the current station belongs to SHUFFLE.

## Bookmarking a Desired Song or Artist

The currently playing track or artist can be bookmarked and saved to your Pandora® account.

### 1 During playback, press **3** (Bookmarks).

The Pandora® Bookmark screen is displayed.

### 2 Turn the Rotary encoder to select "TRACK (Bookmark)" or "ARTIST (Bookmark)", and then press **Q/ENTER**.

The current track or artist is bookmarked. "BOOKMARK TRACK" or "BOOKMARK ARTIST" is displayed.

#### Notes

- Your bookmarks can be viewed on your "Profile" page at [www.pandora.com](http://www.pandora.com).
- In some situations, bookmarks may not be available.
- When Bookmark operation is failed, "PLEASE TRY AGAIN" will be displayed.

## Creating a New Station

Based on currently playing track or artist, you can create a new station and save to your Pandora® account.

### 1 During playback, press **≡** 4 (New Station).

The Pandora® New Station screen is displayed.

### 2 Turn the Rotary encoder to select "TRACK" or "ARTIST", and then press **Q/ENTER**.

A "NEW TRACK" or "NEW ARTIST" pop-up screen.

A New Station based on current track or artist is created.

#### Notes

- Your New Station can be viewed on your "Profile" page at [www.pandora.com](http://www.pandora.com).
- In some situations, creating a new station function may not be available.
- If this operation fails, "PLEASE TRY AGAIN" will be displayed.
- When the Smartphone is not connected to this unit, you can create personalized Pandora® stations using the Pandora® Application on your Smartphone. You can also create stations on the web at [www.pandora.com](http://www.pandora.com).

## Search Position Memory

During playback, you can quickly return to the last-selected hierarchy level in the search mode.

Press **↶**.

The hierarchy you selected last in the search mode is displayed.

## Changing the Display

Press **VIEW**.

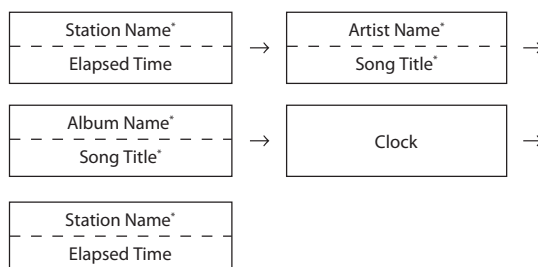

\* TAG information

If there is no text information, nothing will be displayed.

#### Note

- Some characters may not be correctly displayed.



# Information

## In Case of Difficulty

If you encounter a problem, please turn the power off, then on again. If the unit is still not functioning normally, please review the items in the following checklist. This guide will help you isolate the problem if the unit is at fault. Otherwise, make sure the rest of your system is properly connected or consult your authorized Alpine dealer.

### Basic

#### No function or display.

- Vehicle's ignition is off.
  - If connected following instructions, the unit will not operate with the vehicle's ignition off.
- Improper power lead (Red) and battery lead (Yellow) connections.
  - Check power lead and battery lead connections.
- Blown fuse.
  - Check the fuse of the unit; replace with the proper value if necessary.
- Internal micro-computer malfunctioned due to interference noise etc.
  - Press the **RESET** switch with a ballpoint pen or other pointed article.

### Radio

#### Unable to receive stations.

- No antenna or open connection in cable.
  - Make sure the antenna is properly connected; replace the antenna or cable if necessary.

#### Unable to tune stations in the seek mode.

- You are in a weak signal area.
  - Make sure the tuner is in the DX mode.
- If the area you are in is a primary signal area, the antenna may not be grounded and connected properly.
  - Check your antenna connections; make sure the antenna is properly grounded at its mounting location.
- The antenna may not be the proper length.
  - Make sure the antenna is fully extended; if broken, replace the antenna with a new one.

#### Broadcast is noisy.

- The antenna is not the proper length.
  - Extend the antenna fully; replace it if it is broken.
- The antenna is poorly grounded.
  - Make sure the antenna is grounded properly at its mounting location.

### CD

#### CD Player not functioning.

- Out of operating temperature range +50°C (+120°F) for CD.
  - Allow the vehicle's interior (or trunk) temperature to cool.

#### CD playback sound is wavering.

- Moisture condensation in the CD Module.
  - Allow enough time for the condensation to evaporate (about 1 hour).

#### CD insertion not possible.

- A CD is already in the CD player.
  - Eject the CD and remove it.

- The CD is being improperly inserted.
  - Make sure the CD is being inserted following instructions in the CD Player Operation section.

#### Unable to fast forward or backward the CD.

- The CD has been damaged.
  - Eject the CD and discard it; using a damaged CD in your unit can cause damage to the mechanism.

#### CD playback sound skips due to vibration.

- Improper mounting of the unit.
  - Securely re-mount the unit.
- The disc is very dirty.
  - Clean the disc.
- The disc has scratches.
  - Change the disc.
- The pick-up lens is dirty.
  - Do not use a commercially available lens cleaner disc. Consult your nearest Alpine dealer.

#### CD playback sound skips without vibration.

- The disc is dirty or scratched.
  - Clean the disc; damaged disc should be replaced.

#### Error displays (built-in CD player only).

- Mechanical error
  - Press **▲**. After the error indication disappears, insert the disc again. If the above-mentioned solution does not solve the problem, consult your nearest Alpine dealer.

#### CD-R/CD-RW playback not possible.

- Close session (finalization) has not been performed.
  - Perform finalization and attempt playback again.

### MP3/WMA/AAC

#### MP3, WMA or AAC is not played back.

- Writing error occurred. The MP3/WMA/AAC format is not compatible.
  - Make sure the MP3/WMA/AAC has been written in a supported format. Refer to "About MP3/WMA/AAC" on page 14, then rewrite in the format supported by this device.

### Audio

#### The sound is not output from the speakers.

- Unit has no output signal of the internal amplifier.
  - POWER IC is switched to "ON", refer to "Connecting to an External Amplifier (POWER IC)" on page 18.

### iPod

#### iPod does not play and no sound is output.

- The iPod has not been recognized.
  - Reset this unit and the iPod. Refer to "Initial System Start-Up" on page 10. To reset the iPod, refer to the Owner's Manual of the iPod.

### Indication for CD Player

#### NO DISC

- No CD is inserted.
  - Insert a CD.
- Although a disc is inserted, "NO DISC" is displayed and the unit does not start to play or eject the disc.
  - Remove the disc by pressing **▲**:
    - If the disc cannot be ejected by pressing **▲**, press the **RESET** switch (refer to "Initial System Start-Up" on page 10) and press **▲** again. If the disc still cannot be ejected, consult your Alpine dealer.

## ERROR

- Mechanism error.
  - 1 Press the **▲** button and eject the CD.  
If not ejecting, consult your Alpine dealer.
  - 2 When the error indication remains after ejecting, press the **▲** button again.  
If the error indication still does not turn off after pressing the **▲** button, consult your Alpine dealer.
- When "ERROR" is displayed:  
If the disc cannot be ejected by pressing **▲**, press the **RESET** switch (refer to "Initial System Start-Up" on page 10) and press **▲** again.  
If the disc still cannot be ejected, consult your Alpine dealer.

## PROTECT

- A copy-protected WMA file was played back.
  - You can only play back non-copy-protected files.

## UNSUPPORTED

- A sampling rate/bit rate not supported by the unit is used.
  - Use a sampling rate/bit rate that is supported by the unit.

## NO SUPPORT

- Text information that is not recognizable by the unit is being used.
  - Change the text information to text that is supported by the unit.

## Indication for USB Memory

### ERROR

- Communication error or other error.
  - You can solve the problem by switching the source, turning ACC off/on, or turning power off/on.

### ERROR-01

- Communication error.
  - You can solve the problem by switching the source, turning ACC off/on, or turning power off/on.

### ERROR-04

- Abnormal current is run to the USB Memory device.
  - You can solve the problem by turning ACC off/on, or turning power off/on.

## NO USB DEVICE

- A USB Memory is not connected.
  - Make sure the USB Memory device is correctly connected.

## NO FILE

- No song (file) is stored in the USB Memory.
  - Connect the USB Memory device after storing songs (files).

## UNSUPPORTED

- A sampling rate/bit rate not supported by the unit is used.
  - Use a sampling rate/bit rate that is supported by the unit.

## PROTECT

- A copy-protected WMA file was played back.
  - You can only play back non-copy-protected files.

## NO SUPPORT

- Text information that is not recognizable by the unit is being used.
  - Change the text information to text that is supported by the unit.

## DEVICE ERROR

- An unsupported USB device is connected.
  - Change other USB Memory.

## Indication for iPod Mode

### NO SONG

- There are no songs in the iPod/iPhone.
  - Download songs to the iPod/iPhone.

### ERROR-01

- Communication error or boot error, etc.
  - You can solve the problem by switching the source, turning power off/on, or turning ACC off/on.

### ERROR-02

- The iPod/iPhone version is too low.
  - Update the iPod/iPhone version.

### ERROR-03

- The iPod/iPhone is not verified.
  - You can solve the problem by resetting the iPod/iPhone.

### ERROR-04

- Abnormal current is run to the iPod/iPhone.
  - You can solve the problem by reconnecting the iPod/iPhone, turning ACC off/on, or turning power off/on.

## NO USB DEVICE

- The iPod/iPhone is not connected.
  - Make sure the iPod/iPhone is correctly connected and the cable is not bent excessively.

## UPDATING

- The search mode is activated during song downloading.
  - No necessary operation.

## Bluetooth mode

### NO UNIT

- The Bluetooth device is not connected.
  - Connect the Bluetooth device.

## Indication for Pandora® Mode

### NO PANDORA

- A Smartphone is not connected.
  - Make sure a Smartphone is correctly connected.

### CREATE A STATION

- You have not created any personalized Pandora® Stations.
  - When you are not driving, use the Pandora® Compatible Application on the Smartphone to create your Pandora® station(s).

### PANDORA APP ERROR

- The music cannot be played because the Pandora® Compatible Application on the Smartphone requires the user's attention.
  - When you are not driving, please see the Pandora® Compatible Application on the Smartphone.

### NO SERVICE

- You switched CDE-W265EBT/CDE-164EBT to Pandora® mode by pressing **☐/SOURCE** with a Smartphone connected, without launching or installing the Pandora® Application.
  - Launch the Pandora® Application on the Smartphone.
  - Select a source other than Pandora® by pressing **☐/SOURCE**.

### LOGIN TO PANDORA

- The user didn't log in Pandora® account of the Smartphone side.
  - Log in the Pandora® account.

### STATION LIST\_FULL

- The number of new stations reached the limit (100 stations).
  - Delete an existing station.

### UPDATE PANDORAAPP

- You switch CDE-W265EBT/CDE-164EBT to Pandora® mode by pressing **☐/SOURCE** with a Smartphone connected, with an old version Pandora® Compatible Application.
  - Update the Pandora® Compatible Application on the Smartphone.
  - Select a source other than Pandora® by pressing **☐/SOURCE**.

### LIMITED CONNECTION

- A Smartphone in the airplane mode is connected the unit, so that the Pandora® application has limited connectivity and is unable to be active.
  - Make sure the Smartphone is in a mode other than the airplane mode.
  - Wait for the Pandora® application to auto-recover and resume playback.

### NO\_SERVICE AVAILABLE

- Attempt to launch the Pandora® application on the Smartphone from restriction region.
  - Move the vehicle to a location with the Pandora® license.

### STATION N/A

- The searched station is no longer available on Pandora® servers.
  - Select another station to play.

## Specifications

### FM TUNER SECTION

Tuning Range	87.5 ~ 108.0 MHz
Mono Usable Sensitivity	9.3 dBf (0.8 $\mu$ V/75 ohms)
Alternate Channel Selectivity	80 dB
Signal-to-Noise Ratio	65 dB
Stereo Separation	35 dB
Capture Ratio	2.0 dB

### AM TUNER SECTION

Tuning Range	531 ~ 1,602 kHz
Sensitivity (IEC Standard)	22.5 $\mu$ V/27 dB

### CD PLAYER SECTION

Frequency Response	5 ~ 20,000 Hz ( $\pm$ 1 dB)
Wow & Flutter (% WRMS)	Below measurable limits
Total Harmonic Distortion	0.008% (at 1 kHz)
Dynamic Range	95 dB (at 1 kHz)
Signal-to-Noise Ratio	105 dB
Channel Separation	85 dB (at 1 kHz)

### PICKUP

Wave length	795 nm
Laser power	CLASS I

### USB SECTION

USB requirements	USB 1.1/2.0
Max. Power Consumption	Smartphone charge-capable
USB Class	Mass Storage
File System	FAT 12/16/32
MP3 Decoding	MPEG AUDIO Layer-3
WMA Decoding	Windows Media™ Audio
AAC Decoding	AAC-LC format “.m4a” file

### BLUETOOTH SECTION

Bluetooth Specification	Bluetooth v2.1 + EDR
Output Power	+4 dBm Max. (Power class 2)
Profile	HFP (Hands-Free Profile) A2DP (Advanced Audio Distribution Profile) AVRCP (Audio/Video Remote Control Profile)

### GENERAL

Power Requirement	14.4 V DC (11 ~ 16 V allowable)
Maximum Power Output	50 W $\times$ 4
Maximum Pre-Output Voltage	4 V/10 k ohms
Bass	$\pm$ 9.1 dB at 100 Hz
Treble	$\pm$ 9.1 dB at 10 kHz
Weight	1.85 kg (4 lbs. 6 oz) (CDE-W265EBT) 1.4 kg (3 lbs. 1 oz) (CDE-164EBT)

### CHASSIS SIZE (CDE-W265EBT)

Width	178 mm (7")
Height	100 mm (4")
Depth	161.7 mm (6-3/8")

### CHASSIS SIZE (CDE-164EBT)

Width	178 mm (7")
Height	50 mm (2")
Depth	164.7 mm (6-1/2")

### NOSEPIECE SIZE (CDE-W265EBT)

Width	169.8 mm (6-3/4")
Height	95.8 mm (3-3/4")
Depth	26.2 mm (1")

### NOSEPIECE SIZE (CDE-164EBT)

Width	169.8 mm (6-3/4")
Height	45.8 mm (1-13/16")
Depth	24 mm (15/16")

### Note

- Due to continuous product improvement, specifications and design are subject to change without notice.

# Installation and Connections

Before installing or connecting the unit, please read the following and refer to "Operating Instructions" on page 6 for proper use.

## WARNING

### **MAKE THE CORRECT CONNECTIONS.**

Failure to make the proper connections may result in fire or product damage.

### **USE ONLY IN CARS WITH A 12 VOLT NEGATIVE GROUND.**

(Check with your dealer if you are not sure.) Failure to do so may result in fire, etc.

### **BEFORE WIRING, DISCONNECT THE CABLE FROM THE NEGATIVE BATTERY TERMINAL.**

Failure to do so may result in electric shock or injury due to electrical shorts.

### **DO NOT SPLICE INTO ELECTRICAL CABLES.**

Never cut away cable insulation to supply power to other equipment. Doing so will exceed the current carrying capacity of the wire and result in fire or electric shock.

### **DO NOT DAMAGE PIPE OR WIRING WHEN DRILLING HOLES.**

When drilling holes in the chassis for installation, take precautions so as not to contact, damage or obstruct pipes, fuel lines, tanks or electrical wiring. Failure to take such precautions may result in fire.

### **DO NOT USE BOLTS OR NUTS IN THE BRAKE OR STEERING SYSTEMS TO MAKE GROUND CONNECTIONS.**

Bolts or nuts used for the brake or steering systems (or any other safety-related system), or tanks should NEVER be used for installations or ground connections. Using such parts could disable control of the vehicle and cause fire etc.

### **KEEP SMALL OBJECTS SUCH AS BATTERIES OUT OF THE REACH OF CHILDREN.**

Swallowing them may result in serious injury. If swallowed, consult a physician immediately.

### **DO NOT INSTALL IN LOCATIONS WHICH MIGHT HINDER VEHICLE OPERATION, SUCH AS THE STEERING WHEEL OR GEARSHIFT.**

Doing so may obstruct forward vision or hamper movement etc. and results in serious accident.

## CAUTION

### **HAVE THE WIRING AND INSTALLATION DONE BY EXPERTS.**

The wiring and installation of this unit requires special technical skill and experience. To ensure safety, always contact the dealer where you purchased this product to have the work done.

### **USE SPECIFIED ACCESSORY PARTS AND INSTALL THEM SECURELY.**

Be sure to use only the specified accessory parts. Use of other than designated parts may damage this unit internally or may not securely install the unit in place. This may cause parts to become loose resulting in hazards or product failure.

### **ARRANGE THE WIRING SO IT IS NOT CRIMPED OR PINCHED BY A SHARP METAL EDGE.**

Route the cables and wiring away from moving parts (like the seat rails) or sharp or pointed edges. This will prevent crimping and damage to the wiring. If wiring passes through a hole in metal, use a rubber grommet to prevent the wire's insulation from being cut by the metal edge of the hole.

### **DO NOT INSTALL IN LOCATIONS WITH HIGH MOISTURE OR DUST.**

Avoid installing the unit in locations with high incidence of moisture or dust. Moisture or dust that penetrates into this unit may result in product failure.

## PRECAUTIONS

- Be sure to disconnect the cable from the (-) battery post before installing your CDE-W265EBT/CDE-164EBT. This will reduce any chance of damage to the unit in case of a short-circuit.
- Be sure to connect the color coded leads according to the diagram. Incorrect connections may cause the unit to malfunction or damage to the vehicle's electrical system.
- When making connections to the vehicle's electrical system, be aware of the factory installed components (e.g. on-board computer). Do not tap into these leads to provide power for this unit. When connecting the CDE-W265EBT/CDE-164EBT to the fuse box, make sure the fuse for the intended circuit of the CDE-W265EBT/CDE-164EBT has the appropriate amperage. Failure to do so may result in damage to the unit and/or the vehicle. When in doubt, consult your Alpine dealer.
- The CDE-W265EBT/CDE-164EBT uses female RCA-type jacks for connection to other units (e.g. amplifier) having RCA connectors. You may need an adaptor to connect other units. If so, please contact your authorized Alpine dealer for assistance.
- Be sure to connect the speaker (-) leads to the speaker (-) terminal. Never connect left and right channel speaker cables to each other or to the vehicle body.

### **IMPORTANT**

Please record the serial number of your unit in the space provided below and keep it as a permanent record. The serial number or the engraved serial number is located on the bottom of the unit.

SERIAL NUMBER: [	]
INSTALLATION DATE: [	]
INSTALLATION TECHNICIAN: [	]
PLACE OF PURCHASE: [	]

# Installation

## To prevent external noise from entering the audio system.

- Locate the unit and route the leads at least 10 cm away from the car harness.
- Keep the battery power leads as far away from other leads as possible.
- Connect the ground lead securely to a bare metal spot (remove any paint, dirt or grease if necessary) of the car chassis.
- If you add an optional noise suppressor, connect it as far away from the unit as possible. Your Alpine dealer carries various noise suppressors, contact them for further information.
- Your Alpine dealer knows best about noise prevention measures so consult your dealer for further information.

## ⚠ CAUTION

When you install this unit in your car, do not remove the detachable front panel.

If the detachable front panel is removed during installation, you might press too hard and warp the metal plate that holds it in place.

The main unit must be mounted within 35 degrees of the horizontal plane, back to front.

### ■ CDE-W265EBT

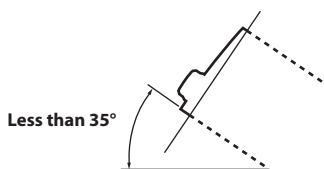

### ■ CDE-164EBT

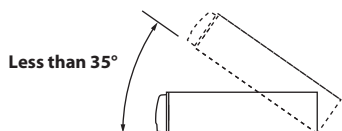

- 1 Remove the mounting sleeve from the main unit (refer to "Removal" on page 49).

### ■ CDE-W265EBT

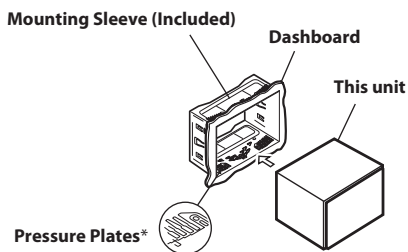

### ■ CDE-164EBT

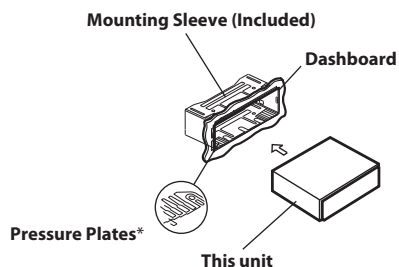

- \* If the installed mounting sleeve is loose in the dashboard, the pressure plates may be bent slightly to remedy the problem.

- 2 Reinforce the head unit with the metal mounting strap (not supplied). Secure the ground lead of the unit to a clean metal spot.

Connect each input lead coming from an amplifier to the corresponding output lead coming from the left rear of the CDE-W265EBT/CDE-164EBT. Connect all other leads of the CDE-W265EBT/CDE-164EBT according to details described in the CONNECTIONS section.

### ■ CDE-W265EBT

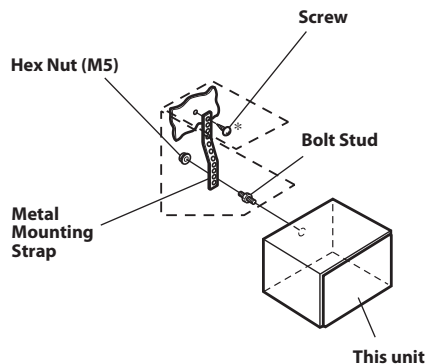

### ■ CDE-164EBT

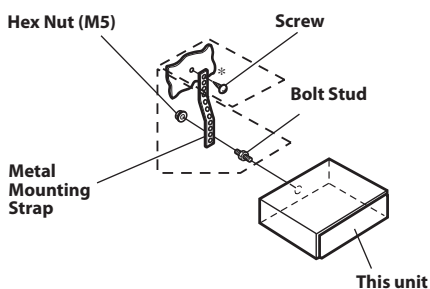

## Note

- For the screw marked "\*", use an appropriate screw for the chosen mounting location.

- 3 Slide the CDE-W265EBT/CDE-164EBT into the dashboard until it clicks. This ensures that the unit is properly locked and will not accidentally come out from the dashboard. Install the detachable front panel.

## Removal

- 1 Remove the detachable front panel.
- 2 Insert the bracket keys into the unit, along the guides on either side. The unit can now be removed from the mounting sleeve.

### CDE-W265EBT

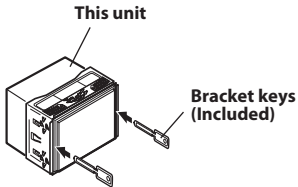

### CDE-164EBT

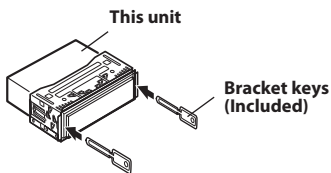

- 3 Pull the unit out, keeping it unlocked as you do so.

JAPANESE CAR

### CDE-W265EBT

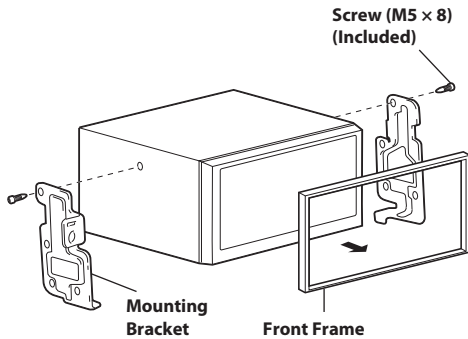

### CDE-164EBT

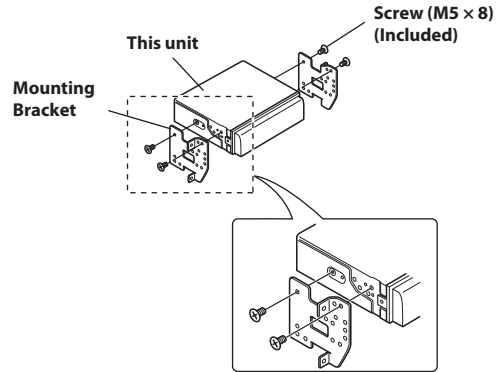
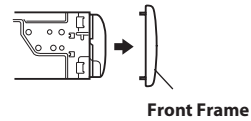

## Mounting the Microphone

For the sake of safety, mount the microphone in the following location.

- In a stable and secure location.
- In a location that does not inhibit safely driving the vehicle.
- Mount the microphone in a location where the driver's voice can easily be picked up.

Choose a location for the microphone that can easily pick up the driver's voice. Requiring the driver to move towards the microphone for audibility causes a distraction that could be dangerous.

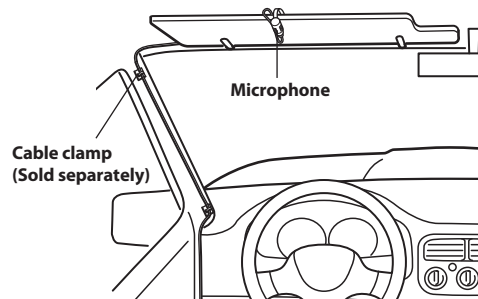

# Connections

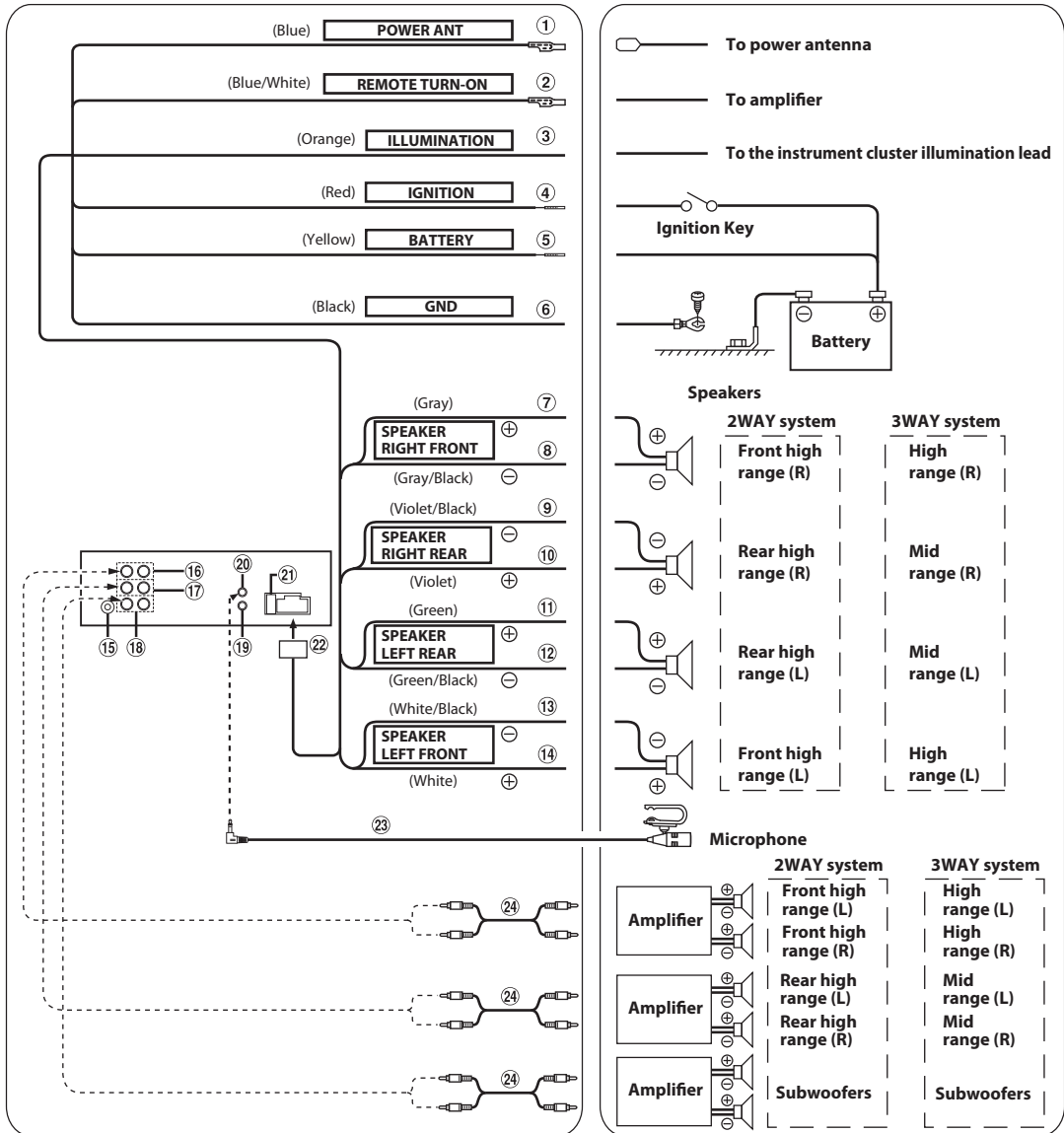

CDE-W265EBT

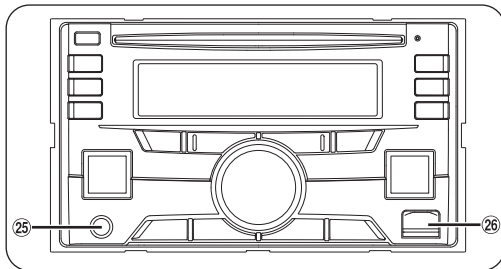

CDE-164EBT

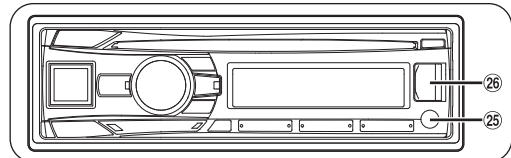



- ① **Power Antenna Lead (Blue)**  
Connect this lead to the +B terminal of your power antenna, if applicable.  
**Note**
  - *This lead should be used only for controlling the vehicle's power antenna. Do not use this lead to turn on an amplifier or a signal processor, etc.*
- ② **Remote Turn-On Lead (Blue/White)**  
Connect this lead to the remote turn-on lead of your amplifier or signal processor.
- ③ **Illumination Lead (Orange)**  
This lead may be connected to the vehicle's instrument cluster illumination lead. This will allow the backlighting of this unit to dim whenever the vehicle's lights are turned on.
- ④ **Switched Power Lead (Ignition) (Red)**  
Connect this lead to an open terminal on the vehicle's fuse box or another unused power source which provides (+) 12V only when the ignition is turned on or in the accessory position.
- ⑤ **Battery Lead (Yellow)**  
Connect this lead to the positive (+) post of the vehicle's battery.
- ⑥ **Ground Lead (Black)**  
Connect this lead to a good chassis ground on the vehicle. Make sure the connection is made to bare metal and is securely fastened using the sheet metal screw provided.
- ⑦ **Right Front (+) Speaker Output Lead (Gray)**
- ⑧ **Right Front (-) Speaker Output Lead (Gray/Black)**
- ⑨ **Right Rear (-) Speaker Output Lead (Violet/Black)**
- ⑩ **Right Rear (+) Speaker Output Lead (Violet)**
- ⑪ **Left Rear (+) Speaker Output Lead (Green)**
- ⑫ **Left Rear (-) Speaker Output Lead (Green/Black)**
- ⑬ **Left Front (-) Speaker Output Lead (White/Black)**
- ⑭ **Left Front (+) Speaker Output Lead (White)**
- ⑮ **Antenna Receptacle**
- ⑯ **Front Output RCA Connectors**  
RED is right and WHITE is left.
- ⑰ **Rear Output RCA Connectors**  
RED is right and WHITE is left.
- ⑱ **Subwoofer Output RCA Connectors**  
RED is right and WHITE is left.
- ⑲ **Steering Remote Control Interface Connector**  
To steering remote control interface box.  
You can operate this unit from the vehicle's control unit when an Alpine Steering Remote Control Interface Box (optional) is connected. For details, contact your Alpine dealer.
- ⑳ **MIC Input Connector**  
To Microphone.
- ㉑ **Fuse Holder (10A)**
- ㉒ **Power Supply Connector**
- ㉓ **Microphone (Supplied)**
- ㉔ **RCA Extension Cable (sold separately)**
- ㉕ **Front AUX Input Terminal**  
This terminal allows for input of audio from an external device (such as a portable player), using a commercially-available converter cable.
- ㉖ **Front USB Terminal**  
Connect this to a USB Memory or to an iPod/iPhone.

**About the Rules of Bluetooth Electromagnetic Radiation Regulation**

<b>Thailand</b>	This telecommunication equipment conforms to NTC technical requirement.	
<b>UAE</b>	<table border="1"><tr><td>TRA REGISTERED No: ER0119686/13 DEALER No: DA0042125/10</td></tr></table>	TRA REGISTERED No: ER0119686/13 DEALER No: DA0042125/10
TRA REGISTERED No: ER0119686/13 DEALER No: DA0042125/10		
<b>OMAN</b>	OMAN-TRA R/1508/13 D100428	